

## Global Flow Control Combination™



TALOAR INC

GATE VALVE CHECK VALVE BUTTERFLY VALVE

# TALOAR

TALOAR Your One Stop

## TALOAR INC SERVES

as a world-leading supplier of flow control products and services, providing a series of diversified fluid control products that are dedicated to commercial, water-related and industrial applications.

The solutions provided by TALOAR INC constitute an important part of the leading plant asset management strategies.



## IN PRODUCTION

as usual TALOAR incorporates the latest mechanical technologies and advanced automation systems to produce and deliver products that can maintain excellent quality.

TALOAR cares and concerns for our users which is not a slogan, but has permeated into our management decisions and actions.

## TALOAR

has provided solutions and technical services for many projects around the world, through which TALOAR has gained valuable project experiences to help users save energy, improve efficiency and offers a green environment. TALOAR has established a good reputation in various industries, has become one of the preferred brand for owners and designers.

*Reliable Partner!*



### INDEX

Product Type	Figure	Pager
Figure Number System		<b>1</b>
Bronze Gate Valves	A107	<b>2</b>
Brass Gate Valves	A103	<b>3</b>
Bronze Globe Valves	G107	<b>4</b>
Brass Globe Valves	G103	<b>5</b>
Bronze Check Valves	C107	<b>6</b>
Bronze Y Strainer	Y107	<b>7</b>
Brass Y Strainer	Y103	<b>8</b>
Bronze Ball Valves	B109	<b>9</b>
Brass Ball Valves	B103	<b>10</b>
Brass Air Vent	VT50	<b>11</b>
Iron Gate Valves	MG670-N	<b>12</b>
Iron Gate Valves	MG670-R	<b>13</b>
Iron Globe Valves	GL670-R	<b>14</b>
Iron Check Valves	CF670-Y	<b>15</b>
Iron Silent Check Valves	CF600-V	<b>16</b>
Iron Y Strainer	YR-670	<b>17</b>
Iron Air Vent	VT-690 / VT-660	<b>18</b>
Ductile Iron Butterfly Valves	HB950-L/G/O	<b>19</b>
Stainless Steel ButterflyValves	HB350-L/G/O	<b>21</b>
Ductile Iron Butterfly Valves	HB960-L/G/O	<b>23</b>
Ductile Iron Butterfly Valves	HB970-L/G/O	<b>25</b>
Electric Butterfly Valves	HB950/S-EH/RH	<b>27</b>
Electric Butterfly Valves	HB960/S-ET/RM	<b>29</b>
Electric Butterfly Valves	HB960/S-EH/RH	<b>31</b>
Electric Butterfly Valves	HB970/S-ET/RM	<b>33</b>
Electric Butterfly Valves	HB970/S-EH/RH	<b>35</b>
Ductile Iron Gate Valves	MG970-N	<b>37</b>
Ductile Iron Gate Valves	MG970-R	<b>38</b>
Ductile Iron Gate Valves	FG970-EN	<b>39</b>
Ductile Iron Gate Valves	FG975-EN	<b>41</b>
Ductile Iron Gate Valves	FG970-ER	<b>42</b>
Ductile Iron Gate Valves	FG975-ER	<b>43</b>
Ductile Iron Globe Valves	GL970-R	<b>44</b>
Ductile Iron Check Valves	CF970-Y	<b>45</b>
Ductile Iron Silent Check Valves	CF970-V	<b>46</b>
Ductile Iron Silent Check Valves	CF975-V	<b>47</b>
Dual Plate Check Valves	CF900-X	<b>48</b>
Ball Non-Return Valves	CF970-B	<b>49</b>
Ductile Iron Y Strainer	YR-970	<b>50</b>
Ductile Iron Y Strainer	YR-975	<b>51</b>
Ductile Iron Foot Valves	TF-970	<b>52</b>
Stainless Steel Air Vent	VT-360	<b>53</b>
Butterfly Valve Torque Operator		<b>54</b> <b>55</b>
Electric Actuators		<b>56</b>
Conversion Tables		<b>58</b>
Installation Tips		<b>59</b>

\* The valves designed and manufactured by TALOAR INC provide ideal and correct solutions in the recommended application fields at the lowest purchasing price and maintenance cost, able to meet and exceed the specified standards developed through years of experienced research and laboratory testing.

### BUILDING VALVES

#### CODE LEGEND

#### Figure Number System of Gate Valves - Globe Valves - Check Valves - Strainers

##### Bronze-Brass Valves

Type	Pressure	End	Body
<b>A</b> - Gate Valve (Non-Rising Stem)	<b>0</b> - 1.6Mpa (235 PSI)	<b>0</b> - Threaded	<b>3</b> - Brass
<b>N</b> - Gate Valve (Rising Stem)	<b>1</b> - 2.0Mpa (300 PSI)	<b>1</b> - Solder	<b>7</b> - Bronze
<b>G</b> - Globe Valve	<b>3</b> - 2.5Mpa (350 PSI)	<b>2</b> - Grooved	
<b>C</b> - Check Valve	<b>5</b> - 4.0Mpa (585 PSI)	<b>3</b> - Flange	
<b>B</b> - Ball Valve			
<b>Y</b> - Strainer			

#### Figure Number System of Butterfly Valves - Gate Valves - Globe Valves - Ball Valves

##### Cast iron - Ductile iron Valves

Type	Body	End	Pressure
<b>HB</b> - Butterfly Valve	<b>3</b> - Stainless Steel	<b>5</b> - Wafer-Type	<b>1</b> - 1.0Mpa(150PSI)
<b>SV</b> - Signal Butterfly Valve	<b>5</b> - Cast Steel	<b>6</b> - Lug Type	<b>0</b> - 1.6Mpa(235PSI)
<b>MG</b> - Gate Valve (Metal Seal)	<b>6</b> - Cast Iron	<b>7</b> - Flanged Type	<b>2</b> - 2.0Mpa(300PSI)
<b>FG</b> - Gate Valve (Rubber Disc)	<b>9</b> - Ductile Iron	<b>8</b> - Grooved Type	<b>3</b> - 2.5Mpa(350PSI)
<b>GL</b> - Globe Valve		<b>9</b> - Threaded Type	
<b>CF</b> - Check Valve			
<b>YR</b> - Strainer			
<b>VT</b> - Vent Valve			
<b>TF</b> - Foot Valve			

**\* Code definitions:**

- <b>L</b> Lever	- <b>G</b> Worm Gear Lever	- <b>X</b> Butterfly Double-Disc Check	- <b>P</b> Single-Disc Check Valve
- <b>R</b> Rising Stem	- <b>O</b> Polished Rod	- <b>Y</b> Swing Check Valve	- <b>B</b> Ball Check Valve
- <b>N</b> Non-Rising Stem	- <b>E</b> Elastic Seat Sealing	- <b>V</b> Center-Oriented Silencing	- <b>S</b> Stainless Steel Disc

\* The figure number systems above are only for reference. The figure number systems vary with valve categories.

\* The valves designed and manufactured by TALOAR INC provide ideal and correct solutions in the recommended application fields at the lowest purchasing price and maintenance cost, able to meet and exceed the specified standards developed through years of experienced research and laboratory testing.

### Bronze Gate Valves

PN20/300PSI/Class150

Screw-In Bonnet, Solid Wedge, Non-Rising Stem  
BSEN12288, Threaded Ends Comply to BS21 or ANSI 2.1

Hydraulic Pressure Test	
Body	3.0Mpa/30Bar
Seat	2.2Mpa/22Bar

Pressure Ratings	
0.9 Mpa at 180°C	
2.0 Mpa at -20°C-100°C	



#### Materials List

No	Part	Specification	BS EN	ASTM
1	Body	Cast Bronze	1982 CC490K	B584 C84400
2	Disc	Cast Bronze	1982 CC490K	B584 C84400
3	Bonnet	Cast Bronze	1982 CC490K	B584 C84400
4	Retaining Nut	Brass	12164 CW603N	B16 C36000
5	Stem Packing	PTFE	PTFE	PTFE
6	Gland	Brass	12164 CW603N	B16 C36000
7	Nut	Brass	12164 CW603N	B16 C36000
8	Stem	Brass	12164 CW603N	B16 C36000
9	Handwheel	Cast Iron	EN-JL1030	A126 CLASS B
10	Handwheel Nut	Steel	--	A563 Zn PLATED
11	Nameplate	Aluminum	--	B209 1100

**A107**

1/2" - 4"

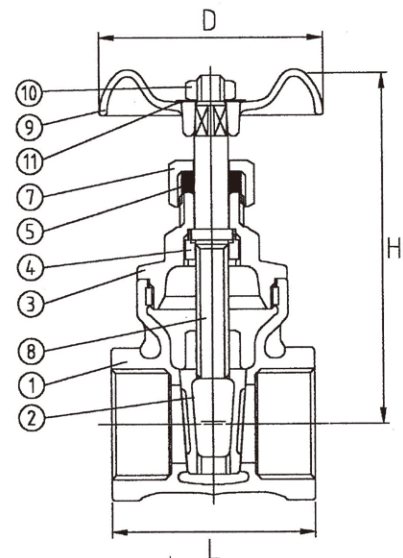

#### Dimensions-Weights

mm	15	20	25	32	40	50	65	80	100	
In	1/2	3/4	1	1 1/4	1 1/2	2	2 1/2	3	4	
L	47.5	51.5	58.6	63	66.5	73.5	90	100	122	
H	78	94	109	120	142	163	207	235	281	
D	53	64	70	80	90	102	104	118	150	
Weight	Lbs	0.66	0.93	1.21	1.79	2.16	3.42	6.62	8.95	14.27
	Kg	0.30	0.42	0.55	0.81	0.98	1.55	3.00	4.06	6.47

\* **Freezing Weather Precaution:** Subsequent to testing a piping system, valves should be left in an open position to allow complete drainage.

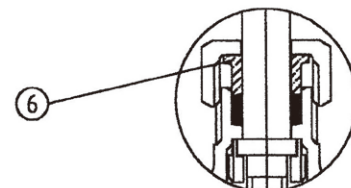

Bonnet construction for sizes 1" - 4"

Each TALORAR bronze valve has been thoroughly cleaned and degreased and packed separately in the sealed polythene bag.

### Brass Gate Valves

PN16/235PSI/Class125

Solid Wedge, Non-Rising Stem

BSEN12288, Threaded Ends Comply to BSPT or ANSI 2.1



Hydraulic Pressure Test	
Body	2.4Mpa/24Bar
Seat	1.76Mpa/17.6Bar

Pressure Ratings	
0.9 Mpa at 180°C	
2.0 Mpa at -20°C-100°C	

#### Materials List

No	Part	Specification	BS EN	ASTM
1	Body	Brass	CW612N	C3700
2	Disc	Brass	CW612N	C3700
3	Bonnet	Brass	CW612N	C3700
5	Stem Packing	PTFE	PTFE	PTFE
6	Gland	Brass	CW603N	C3600
7	Nut	Brass	CW603N	C3600
8	Stem	Brass	CW603N	C3600
9	Handwheel	Cast Iron	EN-JL1030	A126 CLASS B
10	Handwheel Nut	Steel	--	A563 Zn PLATED
11	Nameplate	Aluminum	--	B209 1100

**A103**  
1/2" - 2"

#### Dimensions-Weights

mm	15	20	25	32	40	50	
In	1/2	3/4	1	1 1/4	1 1/2	2	
L	39	45	49	56	56	69	
H (max)	68	73	83	110	108	122	
D	53	60	60	84.5	84	84.5	
P	13	16.5	21	31	37	44	
W	7.5	9	10	11	11	14	
d	7	7	8	9	9	9	
Weight	Lbs	0.42	0.64	0.88	1.7	1.7	2.69
	Kg	0.19	0.29	0.4	0.77	0.77	1.22

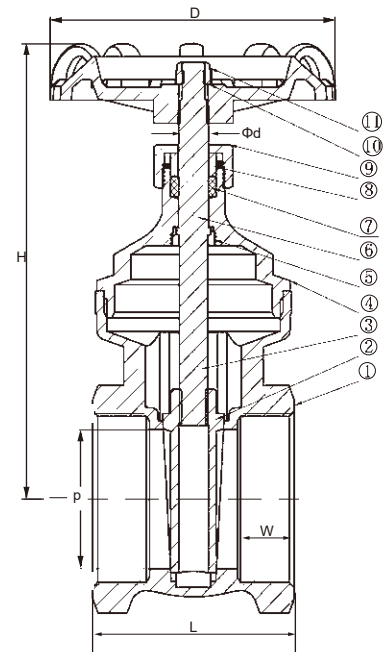

\* **Freezing Weather Precaution:** Subsequent to testing a piping system, valves should be left in an open position to allow complete drainage.

Each TALOAR brass valve has been thoroughly cleaned and degreased and packed separately in the sealed polythene bag.

### Bronze Globe Valves

PN20/300PSI/Class150

BSEN12288, Threaded Ends Comply to BS21 or ANSI 2.1

Hydraulic Pressure Test	
Body	3.0Mpa/30Bar
Seat	2.2Mpa/22Bar

Pressure Ratings	
0.9 Mpa at 180°C	
2.0 Mpa at -20°C-100°C	



**G107**  
1/2" - 3"

#### Materials List

No	Part	Specification	BS EN	ASTM
1	Body	Cast Bronze	1982 CC490K	B584 C84400
2	Disc 1/4" - 1" 1 1/4" - 4"	Brass	12164 CW603N	B16 C36000
		Cast Bronze	1982 CC490K	B584 C84400
3	Bonnet	Cast Bronze	1982 CC490K	B584 C84400
4	Retaining Nut	Brass	12164 CW603N	B16 C36000
5	Stem Packing	PTFE	PTFE	PTFE
6	Gland	Brass	12164 CW603N	B16 C36000
7	Nut	Brass	12164 CW603N	B16 C36000
8	Stem	Brass	12164 CW603N	B16 C36000
9	Handwheel	Cast Iron	EN-JL1030	A126 CLASS B
10	Handwheel Nut	Steel	--	A563 Zn PLATED
11	Nameplate	Aluminum	--	B209 1100

#### Dimensions-Weights

mm	15	20	25	32	40	50	65	80
In	1/2	3/4	1	1 1/4	1 1/2	2	2 1/2	3
L	49	56	65	75	84	99	119	135
H (closed)	70	70	87	94	104	124	154	175
D	53	57.5	64	74	74	87	100	120
Weight	Lbs	0.57	0.77	1.21	1.59	2.23	3.40	8.82
	Kg	0.26	0.35	0.55	0.72	1.01	1.54	4.00

\* **Freezing Weather Precaution:** Subsequent to testing a piping system, valves should be left in an open position to allow complete drainage.

Each TALOAR bronze valve has been thoroughly cleaned and degreased and packed separately in the sealed polythene bag.

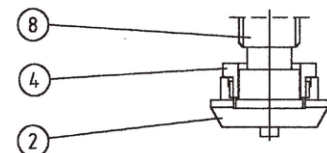
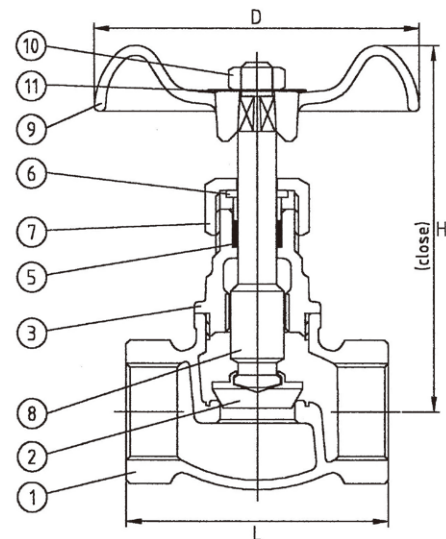

1/4" - 3"

### Brass Globe Valves

PN16/235PSI/Class125

BSEN12288, Threaded Ends Comply to BSPT or ANSI 2.1

Hydraulic Pressure Test	
Body	2.4Mpa/24Bar
Seat	1.76Mpa/17.6Bar

Pressure Ratings	
0.9 Mpa at 180°C	
2.0 Mpa at -20°C-100°C	



**G103**  
1/2" - 2"

#### Materials List

No	Part	Specification	BS EN	ASTM
1	Body	Brass	CW612N	C37700
2	Bonnet	Brass	CW612N	C37700
3	Disc	Brass	CW603N	C36000
4	Stem	Brass	CW603N	C36000
5	Sealing Ring	PTFE	PTFE	PTFE
6	Stem Packing	PTFE	PTFE	PTFE
7	Nut	Brass	CW603N	C36000
8	Handwheel	Cast iron	BSEN 1561	A126 CLASS B
9	Nameplate	Aluminum	--	B209 1100
10	Handwheel Nut	Stainless Steel	BS970 304S15	S30400

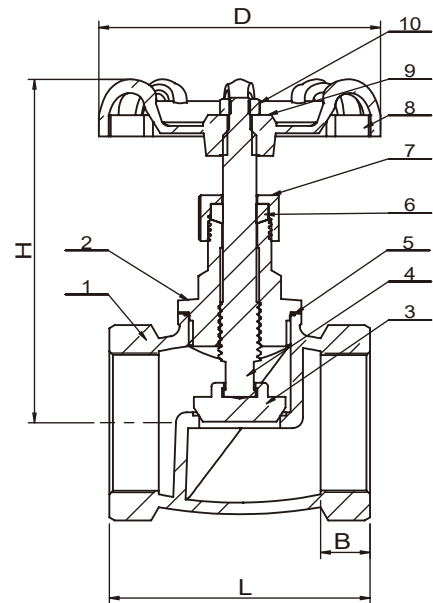

#### Dimensions-Weights

mm	15	20	25	32	40	50	
<b>In</b>	½	¾	1	1¼	1½	2	
<b>L</b>	49	50	60	69.5	76	92	
<b>H (closed)</b>	68	70	73	87	94	108	
<b>D</b>	54	59	59	78	78	92	
<b>B</b>	10	9.5	11.5	12.5	14	16	
<b>Weight</b>	<b>Lbs</b>	0.60	0.64	0.82	1.26	1.65	2.60
	<b>Kg</b>	0.27	0.29	0.37	0.57	0.75	1.18

\* **Freezing Weather Precaution:** Subsequent to testing a piping system, valves should be left in an open position to allow complete drainage.

Each TALOAR brass valve has been thoroughly cleaned and degreased and packed separately in the sealed polythene bag.

### Bronze Check Valves PN20/300PSI/Class150

Horizontal Swing  
BSEN12288, Threaded Ends Comply to BS21 or ANSI 2.1

Hydraulic Pressure Test	
Body	3.0Mpa/30Bar
Seat	2.2Mpa/22Bar

Pressure Ratings	
0.9 Mpa at 180°C	
2.0 Mpa at -20°C-100°C	



**C107**  
1/2" - 4"

#### Materials List

No	Part	Specification	BS EN	ASTM
1	Body	Cast Bronze	1982 CC490K	B584 C84400
2	Disc	Cast Bronze	1982 CC490K	B584 C84400
3	Bonnet	Cast Bronze	1982 CC490K	B584 C84400
4	Hanger Pin	Brass	12164 CW603N	B16 C36000
5	Plug	Brass	12164 CW603N	B16 C36000

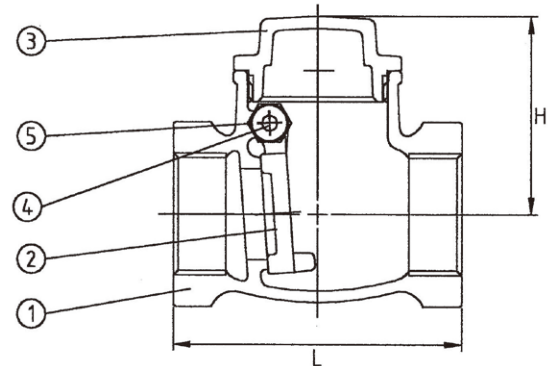

#### Dimensions-Weights

mm	15	20	25	32	40	50	65	80	100	
In	1/2	3/4	1	1 1/4	1 1/2	2	2 1/2	3	4	
L	56	70.5	80	96.5	110	129	138	151	178	
H	39.5	42.5	50	55	60	69.5	90	100	114	
Weight	Lbs	0.51	0.64	0.95	1.43	1.79	2.95	6.06	8.38	13.12
	Kg	0.23	0.29	0.43	0.65	0.81	1.34	2.75	3.80	5.95

\* TALOAR Check Valves may be installed in both horizontal and vertical lines with upward flow or in any intermediate position.

Each TALOAR bronze valve has been thoroughly cleaned and degreased and packed separately in the sealed polythene bag.

### Bronze Y Strainer PN20/300PSI/Class150

BSEN12288, Threaded Ends Comply to BS21 or ANSI 2.1

Hydraulic Pressure Test	
Body	3.0Mpa/30Bar

Pressure Ratings	
0.9 Mpa at 180°C	
2.0 Mpa at -20°C-100°C	



**Y107**  
1/2" - 3"

#### Materials List

No	Part	Specification	BS EN	ASTM
1	Body	Cast Bronze	1982 CC490K	B584 CA844
2	Strainer Screen (20 Mesh)	Stainless Steel	BSEN 10088-1	304 SS 20 MESH
3	Bonnet	Cast Bronze	1982 CC490K	B584 CA844
4	Gasket	NBR	NBR	NBR
5	Plug	Cast Bronze	1982 CC490K	B584 CA844

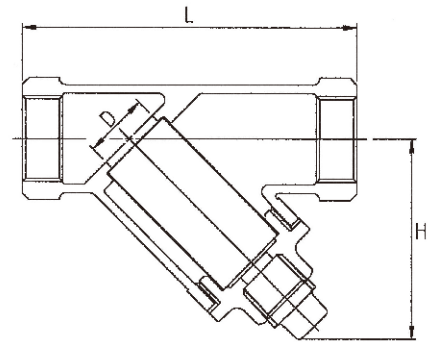

#### Dimensions-Weights

mm	15	20	25	32	40	50	65	80	
In	1/2	3/4	1	1 1/4	1 1/2	2	2 1/2	3	
L	80	100	115	135	160	190	220	265	
H	48.5	58	70	80	93	112	130	146	
D	14	19.5	25	31.8	38.1	50	63.5	76.2	
Weight	Lbs	0.77	1.19	1.87	2.38	4.04	6.35	9.55	13.96
	Kg	0.35	0.54	0.85	1.08	1.83	2.88	4.33	6.33

\* **Freezing Weather Precaution:** Subsequent to testing a piping system, valves should be left in an open position to allow complete drainage.

Each TALOAR bronze valve has been thoroughly cleaned and degreased and packed separately in the sealed polythene bag.

### Brass Y Strainer PN16/235PSI/Class125

BSEN12288, Threaded Ends Comply to BSPT or ANSI 2.1

Hydraulic Pressure Test	
Body	2.4Mpa/24Bar

Pressure Ratings	
0.9 Mpa at 180°C	
2.0 Mpa at -20°C-100°C	



**Y103**  
1/2" - 2"

#### Materials List

No	Part	Specification	BS EN	ASTM
1	Body	Brass	CW612N	C37700
2	Bonnet	Brass	CW612N	C37700
3	Sealing Ring	PTFE	PTFE	PTFE
4	Strainer Screen	Stainless Steel	BSEN 10088-1	304SS 18MESH

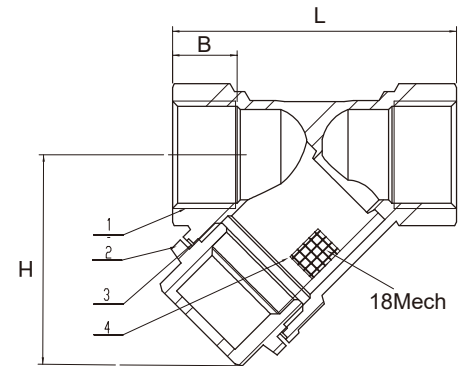

#### Dimensions-Weights

mm		15	20	25	32	40	50
In		1/2	3/4	1	1 1/4	1 1/2	2
L		55	65	80	89.5	100.5	126
H		41	46	55	65	75	91
B		12.5	12.5	15	19	17.5	20
Weight	Lbs	0.35	0.42	0.79	1.21	1.63	2.80
	Kg	0.16	0.19	0.36	0.55	0.74	1.27

Each TALoAR brass valve has been thoroughly cleaned and degreased and packed separately in the sealed polythene bag.

### Bronze Ball Valves PN40/600PSI/Class300

Full-Bore, Chrome-Plated Ball  
BSEN12288, Threaded Ends Comply to BS21 or ANSI 2.1



**B109**  
1/2" - 2"

Hydraulic Pressure Test	
Body	6.0Mpa/60Bar
Seat	4.0Mpa/40Bar

Pressure Ratings	
0.9 Mpa at 180°C	
4.0 Mpa at -20°C-100°C	

#### Materials List

No	Part	Specification	BS EN	ASTM
1	Body	Cast Bronze	1982 CC490K	B584 CA844
2	Ball	Brass	12164 CW603N	B16 CA360
3	End Cap	Cast Bronze	1982 CC490K	B584 CA844
4	Thrust Washer	PTFE	PTFE	PTFE
5	Seat	PTFE	PTFE	PTFE
6	Stem Packing	PTFE	PTFE	PTFE
7	Packing Gland	Brass	12164 CW603N	B16 C3600
8	Stem	Brass	12164 CW603N	B16 C3600
9	Handle	Steel		A107
10	Handle Nut	Steel		A107
11	Handle Sleeve	PE	VINYL	

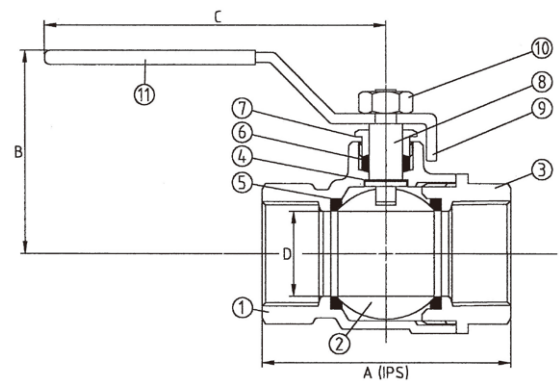

1/2" - 1" Solid Ball  
1 1/4" - 2" Hollow Ball

#### Dimensions-Weights

mm		15	20	25	32	40	50
In		1/2	3/4	1	1 1/4	1 1/2	2
<b>A</b>		54.5	62	73.1	82.5	91.7	106.5
<b>B</b>		46	55	62	70	75	82
<b>C</b>		82	103	105	106	150	160
<b>D</b>		12.7	19	25	31	38	50
<b>Weight</b>	<b>Lbs</b>	0.53	0.82	1.39	1.54	2.87	4.15
	<b>Kg</b>	0.24	0.37	0.63	0.70	1.30	1.88

\* **Freezing Weather Precaution:** Subsequent to testing a piping system, valves should be left in an open position to allow complete drainage.

Each TALOAR bronze valve has been thoroughly cleaned and degreased and packed separately in the sealed polythene bag.

### Brass Ball Valves PN16/235PSI

Chrome-Plated Ball  
BSEN12288, Threaded Ends Comply to BSPT or ANSI 2.1



**B103**  
1/2" - 2"

Hydraulic Pressure Test	
Body	2.4Mpa/24Bar
Seat	1.76Mpa/17.6Bar

Pressure Ratings	
	0.9 Mpa at 180°C
	2.5 Mpa at -20°C-100°C

#### Materials List

No	Part	Specification	BS EN	ASTM
1	Body	Brass	CW612N	C37700
2	End Cap	Brass	CW612N	C37700
3	Seat	PTFE	PTFE	PTFE
4	Ball	Nickel-Plated Brass	CW603N	C36000
5	Stem	Brass	CW603N	C36000
6	Sealing Ring	NBR	NBR	NBR
7	Stem Packing	PTFE	PTFE	PTFE
8	Packing Gland	Brass	CW603N	C36000
9	Handle	Steel	--	A107
10	Handle Nut	Steel	--	A107

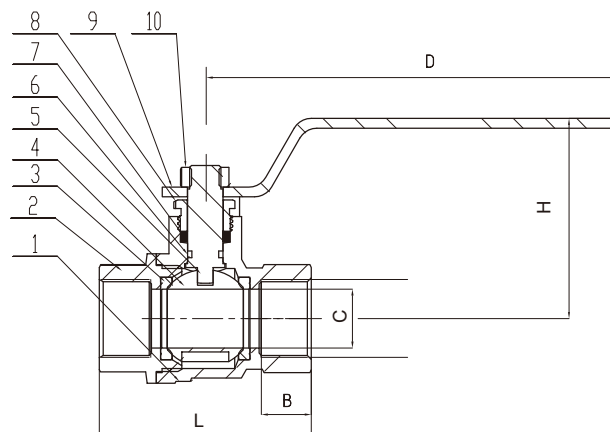

#### Dimensions-Weights

mm		15	20	25	32	40	50
In		1/2	3/4	1	1 1/4	1 1/2	2
L		54	56	66.5	79.5	86.5	107
B		12.7	17	19	12	26	29
C		15	19	22	30	32	42
H		51	55	65	69	73	92
D		105	107	136	136	136	164
Weight	Lbs	0.60	0.62	0.97	1.32	1.74	3.06
	Kg	0.27	0.28	0.44	0.6	0.79	1.39

\* **Freezing Weather Precaution:** Subsequent to testing a piping system, valves should be left in an open position to allow complete drainage.

Each TALOAR brass valve has been thoroughly cleaned and degreased and packed separately in the sealed polythene bag.

### Brass Air Vent PN16/235PSI

Threaded Ends Comply to BS21 or ANSI 2.1

Hydraulic Pressure Test	
Body	2.4Mpa/24Bar

#### Materials List

Part	Specification	BS EN	ASTM
Body	Brass	12164 CW603N	B16 C36000
Bonnet	Brass	12164 CW603N	B16 C36000
Float	PP	PP	PP
Lever	Stainless Steel	304 SS	304 SS
Bonnet Seal	NBR	NBR	NBR
Vent Cap	Brass	12164 CW603N	B16 C36000

#### Dimensions-Weights

mm		10	15	20	25
In		3/8	1/2	3/4	1
H		79	79	79	81
D		48	48	48	48
h		11	11	11	13
Weight	Lbs	0.44	0.44	0.46	0.49
	Kg	0.20	0.20	0.21	0.22



**VT50**  
3/8" - 1"

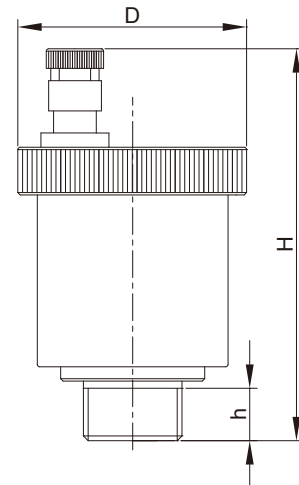

#### Installation tip!

Vent valves should be vertically installed on the top of piping devices.

Each TALOAR brass valve has been thoroughly cleaned and degreased and packed separately in the sealed polythene bag.

### Iron Gate Valves

PN16/235PSI/Class125

Non-Rising Stem, Solid Wedge, Bronze Seat  
 Design to BS5150 and MSS SP-70  
 Flange Dimension to EN1092-2, ANSI B16.1 Class 125

Hydraulic Pressure Test	
Body	2.4Mpa/24Bar
Seat	1.76Mpa/17.6Bar

Pressure Ratings	
	1.0 Mpa at 180°C
	1.6 Mpa at -10°C-120°C



**MG670-N**  
2" - 24"

#### Materials List

No	Part	Specification	BS EN	ASTM
1	Body	Cast Iron	BSEN 1561	A126 Class B
2	Seat Sealing Ring	Cast Bronze	1982 CC491K	B62
3	Disc Sealing Ring	Cast Bronze	1982 CC491K	B62
4	Disc	Cast Iron	BSEN 1561	A126 Class B
5	Stem Nut	Brass	12164 CW603N	B16
6	Stem	Brass	12164 CW603N	B16
7	Gasket	Graphite	---	--
8	Bolt	Steel	BSEN 10087	Steel A307
9	Nut	Steel	BSEN 10087	Steel A307
10	Bonnet	Cast Iron	BSEN 1561	A126 Class B
11	Stud	Steel	BSEN 10087	Steel A307
12	Nut	Steel	BSEN 10087	Steel A307
13	Gland Box Gasket	Graphite	---	--
14	Gland Box	Cast iron	BSEN 1561	A126 Class B
15	Packing	Graphite	---	--
16	Seal Gland	Ductile Iron	BSEN 1563	A536 65-45-12
17	Handwheel	Cast Iron	BSEN 1561	A126 Class B
18-19	Gasket	Steel	BSEN 10087	Steel A307
20	Nut	Steel	BSEN 10087	Steel A307

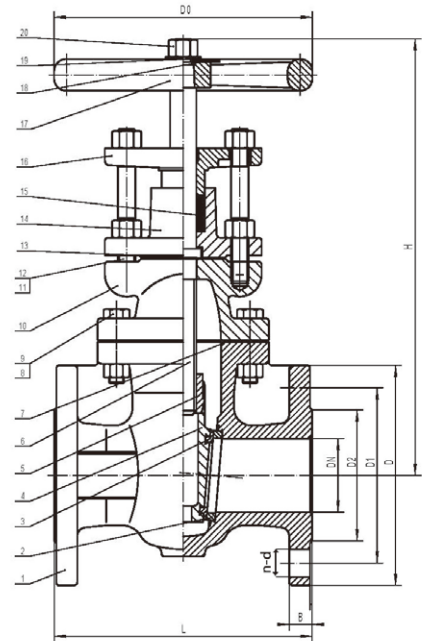

#### Dimensions-Weights

mm	50	65	80	100	125	150	200	250	300	350	400	450	500	600	
In	2	2½	3	4	5	6	8	10	12	14	16	18	20	24	
L	178	190	203	229	254	267	292	330	356	381	406	432	457	508	
H	302	332	335	423	485	545	644	769	860	987	1044	1148	1257	1418	
D	165	185	200	220	250	285	340	405	460	520	580	640	715	840	
D1	125	145	160	180	210	240	295	355	410	470	525	585	650	770	
D2	99	118	132	156	184	211	266	319	370	429	480	548	609	720	
D0	178	178	200	254	300	300	348	400	457	560	560	610	610	765	
B	20	20	22	24	26	26	30	32	32	36	38	40	42	48	
n-d	4-19	4-19	8-19	8-19	8-19	8-23	12-23	12-28	12-28	16-28	16-31	20-31	20-34	20-37	
Weight	Lbs	36	48	58	104	150	192	260	434	606	816	1039	1400	1764	2646
	Kg	17	22	27	47	68	87	118	197	275	370	471	635	800	1200

### Iron Gate Valves

PN16/235PSI/Class125

Outside Screw and Yoke, Solid Wedge, Bronze Seat

Design to BS5150 and MSS SP-70

Flange Dimension to EN1092-2, ANSI B16.1 Class 125



**MG670-R**  
2" - 24"

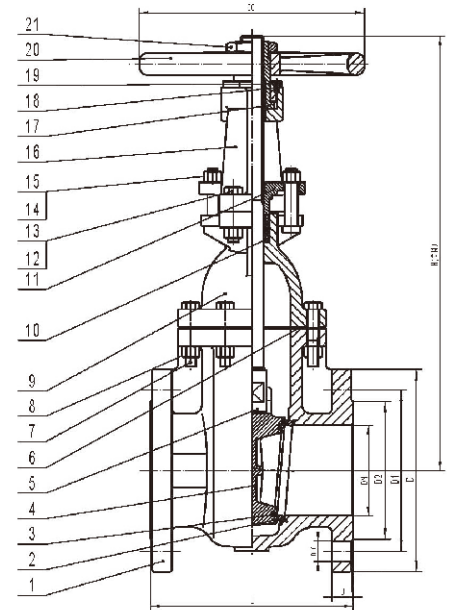

Hydraulic Pressure Test	
Body	2.4Mpa/24Bar
Seat	1.76Mpa/17.6Bar

Pressure Ratings	
1.0 Mpa at 180°C	
1.6 Mpa at -10°C-120°C	

#### Materials List

No	Part	Specification	BS EN	ASTM
1	Body	Cast Iron	BSEN 1561	A126 Class B
2	Seat Sealing Ring	Cast Bronze	1982 CC491K	B62
3	Disc Sealing Ring	Cast Bronze	1982 CC491K	B62
4	Disc	Cast Iron	BSEN 1561	A126 Class B
5	Stem	Brass	12164 CW603N	B16
6	Gasket	Graphite	--	--
7	Bolt	Steel	BSEN 10087	Steel A307
8	Nut	Steel	BSEN 10087	Steel A307
9	Bonnet	Cast Iron	BSEN 1561	A126 Class B
10	Packing	Graphite	--	--
11	Seal Gland	Ductile Iron	BSEN 1563	A536 65-45-12
12	Bolt	Steel	BSEN 10087	Steel A307
13	Nut	Steel	BSEN 10087	Steel A307
14	Gland Bolt	Steel	BSEN 10087	Steel A307
15	Gland Nut	Steel	BSEN 10087	Steel A307
16	Yoke	Cast Iron	BSEN 1561	A126 Class B
17	Yoke Bushing	Brass	12164 CW603N	B16
18	Screw	Steel	BSEN 10087	Steel A307
19	Yoke Nut	Cast Iron	BSEN 1561	A126 Class B
20	Handwheel	Cast Iron	BSEN 1561	A126 Class B
21	Handwheel Nut	Steel	BSEN 10087	Steel A307

#### Dimensions-Weights

mm	50	65	80	100	125	150	200	250	300	350	400	450	500	600
In	2	2½	3	4	5	6	8	10	12	14	16	18	20	24
L	178	190	203	229	254	267	292	330	356	381	406	432	457	508
H	311	347	384	490	541	656	778	933	1102	1259	1395	1560	1708	1990
D	165	185	200	220	250	285	340	405	460	520	580	640	715	840
D1	125	145	160	180	210	240	295	355	410	470	525	585	650	770
D2	99	118	132	156	184	211	266	319	370	429	480	548	609	720
D0	178	178	200	254	300	300	348	400	457	560	560	610	610	765
B	20	20	22	24	26	26	30	32	32	36	38	40	42	48
n-d	4-19	4-19	8-19	8-19	8-19	8-23	12-23	12-28	12-28	16-28	16-31	20-31	20-34	20-37
Weight	Lbs	38	51	62	110	154	203	284	459	637	838	1014	1484	2701
	Kg	17	23	28	50	70	92	129	208	289	380	460	673	1225

### Iron Globe Valves PN16/235PSI/Class125

Outside Screw and Yoke, Bronze Seat  
Design to BS5152 and MSS SP-85  
Flange Dimension to EN1092-2, ANSI B16.1 Class 125

Hydraulic Pressure Test	
Body	2.4Mpa/24Bar
Seat	1.76Mpa/17.6Bar

Pressure Ratings	
	1.0 Mpa at 180°C
	1.6 Mpa at -10°C-120°C

#### Materials List

No	Part	Specification	BS EN	ASTM
1	Body	Cast Iron	BSEN 1561	A126 Class B
2	Seat Sealing Ring	Cast Bronze	1982 CC491K	B62
3	Disc Sealing Ring	Cast Bronze	1982 CC491K	B62
4	Disc	Cast Iron	BSEN 1561	A126 Class B
5	Thrust Washer	Stainless Steel	BSEN 10088-1	AISI 304
6	Nut	Cast Brass	12164 CW603N	B16
7	Stem	Brass	12164 CW603N	B16
8	Flange Gasket	Graphite	---	--
9	Bolt	Steel	BSEN 10087	Steel A307
10	Packing	Graphite	---	--
11	Bonnet	Cast Iron	BSEN 1561	A126 Class B
12	Seal Gland	Ductile Iron	BSEN 1563	A536 65-45-12
13	Nut	Steel	BSEN 10087	Steel A307
14	Bolt	Steel	BSEN 10087	Steel A307
15	Stem Nut	Cast Brass	12164 CW603N	B16
16	Handwheel	Cast Iron	BSEN 1561	A126 Class B
17	Gasket	Steel	BSEN 10087	Steel A307
18	Nut	Steel	BSEN 10087	Steel A307



**GL670-R**  
2" - 12"

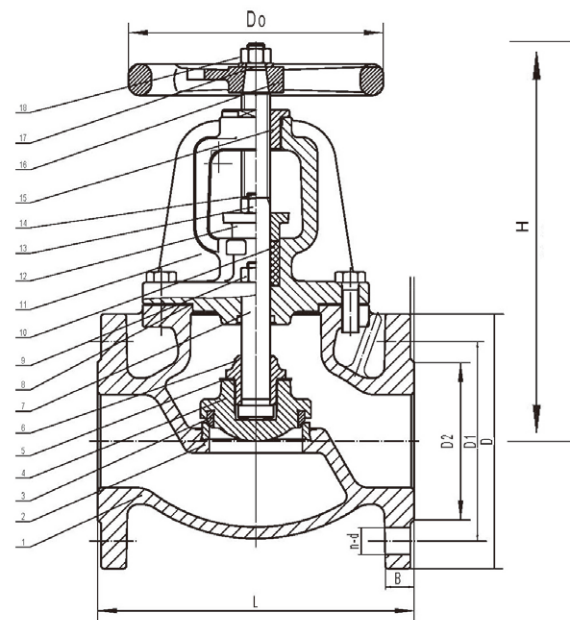

#### Dimensions-Weights

mm	50	65	80	100	125	150	200	250	300
In	2	2½	3	4	5	6	8	10	12
L	203	216	241	292	330	356	495	622	699
H	315	345	387	490	576	680	808	1010	1080
D	165	185	200	220	250	285	340	405	460
D1	125	145	160	180	210	240	295	355	410
D2	99	118	132	156	184	211	266	319	370
D0	178	178	200	254	300	300	348	400	457
B	20	20	22	24	26	26	30	32	32
n-d	4-19	4-19	8-19	8-19	8-19	8-23	12-23	12-28	12-28
Weight	Lbs	34	47	68	99	151	204	683	673
	Kg	16	22	31	45	68	93	219	305

# Iron Check Valves

## PN16/235PSI/Class125

Horizontal Swing, Bronze Seat  
 Design to BS5153 and MSS SP-71  
 Flange Dimension to EN1092-2, ANSI B16.1 Class 125



**CF670-Y**  
 2" - 24"

Hydraulic Pressure Test	
Body	2.4Mpa/24Bar
Seat	1.76Mpa/17.6Bar

Pressure Ratings	
	1.0 Mpa at 180°C
	1.6 Mpa at -10°C-120°C

### Materials List

No	Part	Specification	BS EN	ASTM
1	Body	Cast Iron	BSEN 1561	A126 Class B
2	Seat Sealing Ring	Cast Bronze	1982 CC491K	B62
3	Disc Sealing Ring	Cast Bronze	1982 CC491K	B62
4	Disc	Cast Iron	BSEN 1561	A126 Class B
5	Support	Ductile Iron	BSEN 1563	A536 65-45-12
6	Gasket	Steel	BSEN 10087	Steel A307
7	Nut	Steel	BSEN 10087	Steel A307
8	Safety Pin	Stainless Steel	BSEN 10088-1	AISI 304
9	Screw	Steel	BSEN 10087	Steel A307
10	Support Pin	Brass	12164 CW603N	B16
11	Gasket	Steel	BSEN 10087	Steel A307
12	Safety Pin	Stainless Steel	BSEN 10088-1	AISI 304
13	Bonnet	Cast iron	BSEN 1561	A126 Class B
14	Bonnet Gasket	Graphite	---	--
15	Bolt	Steel	BSEN 10087	Steel A307
16	Nut	Steel	BSEN 10087	Steel A307

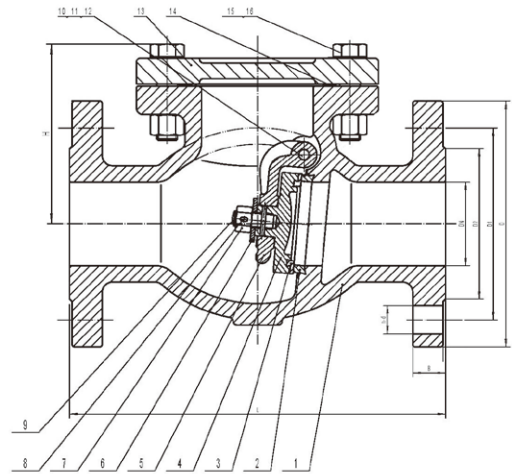

### Dimensions-Weights

mm	50	65	80	100	125	150	200	250	300	350	400	450	500	600
In	2	2½	3	4	5	6	8	10	12	14	16	18	20	24
L	203	216	241	292	330	356	495	622	699	787	914	914	1016	1219
H	112	132	141	162	192	211	270	316	357	560	589	645	702	812
D	165	185	200	220	250	285	340	405	460	520	580	640	715	840
D1	125	145	160	180	210	240	295	355	410	470	525	585	650	770
D2	99	118	132	156	184	211	266	319	370	429	480	548	609	720
B	20	20	22	24	26	26	30	32	32	36	38	40	42	48
n-d	4-19	4-19	8-19	8-19	8-19	8-23	12-23	12-28	12-28	16-28	16-31	20-31	20-34	20-37
Weight	Lbs	26	39	47	82	160	271	443	642	935	1195	1446	1835	2778
	Kg	12	18	21	37	56	72	123	291	424	542	656	832	1260

### Iron Silent Check Valves

PN16/235PSI/Class 125

Wafer Style, Center-Oriented, Spring Actuated  
Flange Dimension to EN1092-2, ANSI B16.1 Class 125



**CF600-V**  
2" - 12"

Hydraulic Pressure Test	
Body	2.4Mpa/24Bar
Seat	1.76Mpa/17.6Bar

Pressure Ratings	
	1.0 Mpa at 180°C
	1.6 Mpa at -10°C-120°C

#### Materials List

No	Part	Specification	BS EN	ASTM
1	Body	Cast Iron	BSEN 1561	A126 Class B
2	Bushing	Cast Bronze	1982 CC491K	B62
3	Spring	Stainless Steel	BSEN 10088-1	AISI 304
4	Disc	Cast Bronze	1982 CC491K	B62
5	Sealing Ring	Rubber	NBR/EPDM	NBR/EPDM
6	Seat	Cast Bronze	1982 CC491K	B62
7	Sealing Ring	Rubber	NBR/EPDM	NBR/EPDM
8	Screw	Stainless Steel	BSEN 10088-1	AISI 304

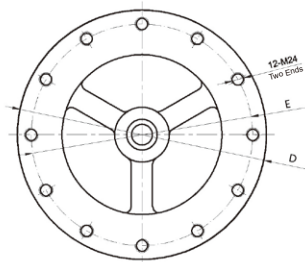
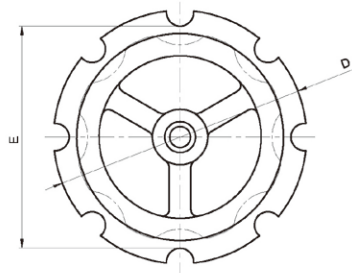

Structure Diagram (12")

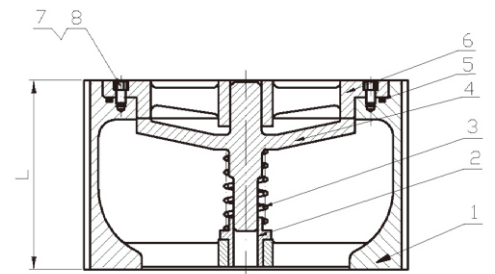

#### Dimensions-Weights

mm		50	65	80	100	125	150	200	250	300
In		2	2½	3	4	5	6	8	10	12
L		67	73	79	102	118	141	165	210	286
D	EN1092-2	108	128	148	178	210	243	336	402	460
	ANSI	108	127	146	178	213	248	343	406	486
E	EN1092-2	106	126	141	161	191	217	271	327	410
	ANSI	100	121	133	171	191	220	276	337	432
Weight	Lbs	7	9	13	22	33	44	86	176	309
	Kg	3	4	6	10	15	20	39	80	140

#### Notes:

\* Silent check valves should be installed at the outlets of pumps.

\* Valves may be installed in any positions of horizontal or vertical pipelines. Not applicable to air compression pipelines.

### Iron Y Strainer PN16/235PSI/Class125

Stainless Steel Screen, Drain Outlet  
Flange Dimension to EN1092-2, ANSI B16.1



**YR-670**  
2" - 16"

Hydraulic Pressure Test	
Body	2.4Mpa/24Bar

Pressure Ratings	
1.0 Mpa at 180°C	
1.6 Mpa at -10°C-120°C	

#### Materials List

No	Part	Specification	BS EN	ASTM
1	Body	Cast Iron	BSEN 1561	A126 Class B
2	Screen	Stainless Steel	BSEN 10088-1	AISI 304
3	Bonnet	Cast Iron	BSEN 1561	A126 Class B
4	Gasket	Graphite	--	--
5	Drain Plug	Cast Iron	BSEN 1561	A126 Class B
6	Bolt	Steel	BSEN 10087	Steel A307

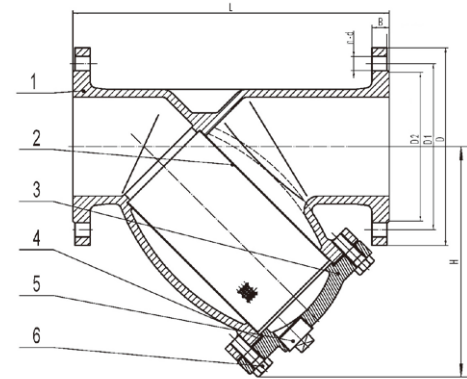

#### Dimensions-Weights

mm	50	65	80	100	125	150	200	250	300	350	400
In	2	2½	3	4	5	6	8	10	12	14	16
L	230	290	310	350	400	480	600	730	850	980	1100
H	156	176	199	240	292	320	399	516	568	648	759
D	165	185	200	220	250	285	340	405	460	520	580
D1	125	145	160	180	210	240	295	355	410	470	525
D2	99	118	132	156	184	211	266	319	370	429	480
B	20	20	22	24	26	26	30	32	32	36	38
n-d	4-19	4-19	8-19	8-19	8-19	8-23	12-23	12-28	12-28	16-28	16-31
Weight	Lbs	22	31	45	59	88	126	214	361	515	688
	Kg	10	14	20	27	40	57	97	164	234	312

### Iron Air Vent PN16/235PSI

Large Venting Volume, Stainless Steel Float  
Dimension to EN1092-2, ANSI B16.1 Class125  
Threaded Ends Comply to BS21 or ANSI 2.1

Maximum Pressure Range	
1/2" - 1"	7-12Bar
2" - 4"	10Bar

Maximum Temperature Range	
1/2" - 1"	120°C/220 °C
2" - 4"	-10°C-80°C

#### Materials List

No	Part	Specification	BS EN	ASTM
1	Bonnet	Cast Iron	BSEN 1561	A126 Class B
2	Seat	Stainless Steel	BS970 304S15	AISI 304
3	Vent Plug	Rubber	EPDM/ VITON	EPDM/ VITON
4	Float	Stainless Steel	BS970 304S15	AISI 304
5	Body	Cast Iron	BSEN 1561	A126 Class B



**VT-690**  
1/2" - 1"



**VT-660**  
2" - 4"

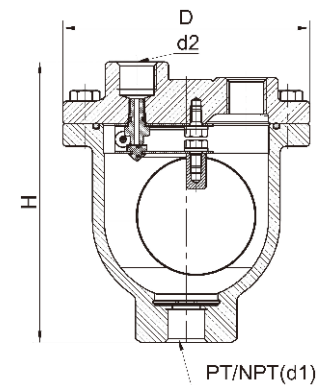
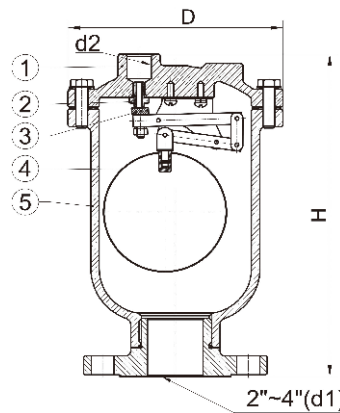

#### Dimensions-Weights

mm	15	20	25	50	65	80	100
In	1/2	3/4	1	2	2 1/2	3	4
H	143	143	155.5	275	275	306	306
D	125	125	150	178	178	250	250
d1	1/2" PT/NPT	3/4" PT/NPT	1" PT/NPT	2" Flg	2 1/2" Flg	3" Flg	4" Flg
d2	3/8" or 1/2" BSPT/NPT						
Weight	Lbs	6.62	6.62	10.58	22	31	53
	Kg	3	3	4.8	10	14	24

#### Installation tip!

Vent valves should be vertically installed on the top of piping devices.

### Ductile Iron Butterfly Valves PN16/235PSI/Class125

Wafer Style, Pin-Free Valve Shaft, Seal-Line Seat  
Design to BS5155 and MSS SP-67  
Flange Dimension to EN1092-2, ANSI B16.1 Class 125



**HB950-L/G/O**  
2" - 12"

Sealing Performance	
EPDM	-20°C- 120°C
NBR	-10°C- 80°C
VITON	-20°C- 150°C

Hydraulic Pressure Test	
Body	2.4Mpa/24Bar
Seat	1.76Mpa/17.6Bar

#### Materials List

No	Part	Specification	BS EN	ASTM
1	Body	Ductile Iron	BSEN 1563	A536 65-45-12
2	Bottom Stem	Stainless Steel	BSEN 10088-1	A582 420
3	O-Ring	NBR	NBR	NBR
4	Seat	EPDM	EPDM	EPDM
		NBR	NBR	NBR
		VITON	VITON	VITON
5	Disc	Ductile Iron	BSEN 1563	A536 65-45-12
		Stainless Steel	BS970 304S15	CF8
		Aluminum Bronze	1400AB2	B148 Ay 954
6	Upper Stem	Stainless Steel	BSEN 10088-1	A582 420
7	Bushing	Composite Material	PTFE&Bronze	PTFE&Bronze
8	Screw	Steel	BSEN 10087	A307
9	Retaining Cap	Steel	BSEN 10087	A307

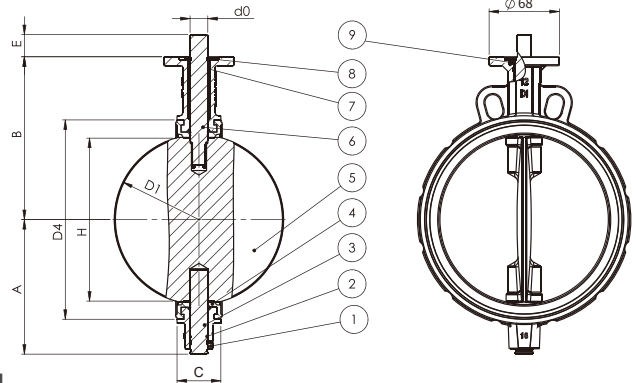
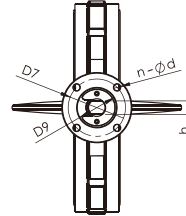

\* Suffix - L for operation by lever, - G for operation by worm gear, - O for polished rod  
\* An electric or pneumatic actuator may be mounted to match an ISO5211-based mount.  
Please refer to the TALOAR Butterfly Valve Torque Table in Page 50.

#### Dimensions-Weights

mm	50	65	80	100	125	150	200	250	300	
In	2	2½	3	4	5	6	8	10	12	
A	78	90	99	120	134	142	178	203	240	
B	120	137	145	160	175	189	220	250	290	
C	43	46	46	52	56	56	62	68	78	
E	30	30	30	30	30	30	40	40	40	
H	40	43	60.3	87.3	106.5	142.3	193.2	242.2	290.2	
D4	83	95.5	138.0	139.0	167.0	194.0	247.6	300.0	352.0	
d0	12.60	12.60	12.60	15.77	18.92	18.92	22.10	28.45	31.60	
h	9	9	9	11	14	14	17	22	24	
D6	90	90	90	90	90	90	125	125	125	
D7	70	70	70	70	70	70	102	102	102	
D9	55	55	55	55	55	55	70	70	70	
n-Φd	4-10	4-10	4-10	4-10	4-10	4-10	4-12	4-12	4-12	
ISO5211	F07	F07	F07	F07	F07	F07	F10	F10	F10	
Weight	Lbs	7.7	8.8	10.1	12.6	16.3	22.3	40.1	52.5	81.6
	Kg	3.5	4.0	4.6	5.7	7.4	10.1	18.2	23.8	37.0

Note: Steam services are not recommended. For valves over 6" , operation by the worm gear is suggested.

### Ductile Iron Butterfly Valves PN16/235PSI/Class125

Wafer Style, Pin-Free Valve Shaft, Seal-Line Seat  
Design to BS5155 and MSS SP-67  
Flange Dimension to EN1092-2, ANSI B16.1 Class 125



**HB950-G/O**  
14" - 32"

Sealing Performance	
EPDM	-20°C- 120°C
NBR	-10°C- 80°C
VITON	-20°C- 150°C

Hydraulic Pressure Test	
Body	2.4Mpa/24Bar
Seat	1.76Mpa/17.6Bar

#### Materials List

No	Part	Specification	BS EN	ASTM
1	Body	Ductile Iron	BSEN 1563	A536 65-45-12
2	Bottom Stem	Stainless Steel	BSEN 10088-1	A582 420
3	Disc	Ductile Iron	BSEN 1563	A536 65-45-12
		Stainless Steel	BS970 304S15	CF8
		Aluminum Bronze	1400AB2	B148 Ay 954
4	Upper Stem	Stainless Steel	BSEN 10088-1	A582 420
5	Seat	EPDM	EPDM	EPDM
		NBR	NBR	NBR
		VITON	VITON	VITON
6	Bushing	Composite Material	PTFE&Bronze	PTFE&Bronze
7	Retaining Cap	Steel	BSEN 10087	A307
8	Worm Gear Box	Ductile Iron	BSEN 1563	A536 65-45-12

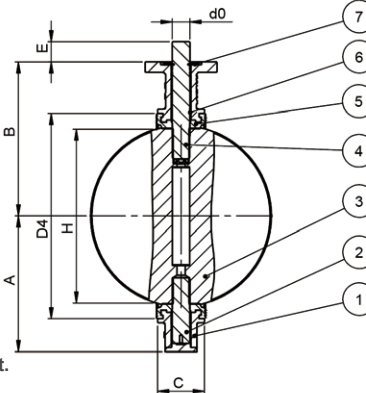
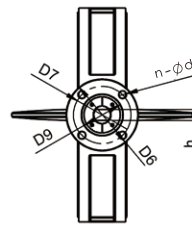

\* Suffix - G for operation by worm gear, - O for polished rod  
\* An electric or pneumatic actuator may be mounted to match an ISO5211-based mount.  
Please refer to the TALORAR Butterfly Valve Torque Table in Page 50.

#### Dimensions-Weights

mm	350	400	450	500	600	700	800
In	14	16	18	20	24	28	32
A	272	296	330	360	447	517	567
B	320	340	375	430	564	616	666
C	78	102	114	127	154	165	190
E	45	50	50	60	60	80	80
H	322.6	374.4	424.2	473.2	572.0	673.0	774.0
D4	404	450	500	555	660	775	875
d0	31.60	37.95	42.86	45.72	53.98	63.35	63.35
h	24	27	27	32	36	Key18*2	Key18*2
D6	125	175	175	175	210	300	300
D7	102	140	140	140	165	254	254
D9	70	100	100	100	130	130	130
n-φd	4-12	4-18	4-18	4-18	4-23	8-18	8-18
ISO5211	F10	F14	F14	F14	F16	F25	F25
Weight	Lbs	101	152	196	307	419	926
	Kg	46	69	89	139	190	420

Note: Steam services are not recommended.

# Stainless Steel Butterfly Valves

## PN16/235PSI/Class125

**Wafer Style**  
**Design to EN953 and MSS SP-67**  
**Flange Dimension to EN1092-2, ANSI B16.1 Class 125**



**HB350-L/G/O**  
**2" - 12"**

Sealing Performance	
EPDM	-20°C- 120°C
NBR	-10°C- 80°C
VITON	-20°C- 150°C

Hydraulic Pressure Test	
Body	2.4Mpa/24Bar
Seat	1.76Mpa/17.6Bar

### Materials List

No	Part	Specification	BS EN	ASTM
1	Body	Stainless Steel	BS970 316 BS970 304	CF8M CF8
2	Disc	Stainless Steel	BS970 316 BS970 304	CF8M CF8
3	Seat	EPDM NBR VITON	EPDM NBR VITON	EPDM NBR VITON
4	Shaft	Stainless Steel	BSEN 10088-1	A582 420
5	Bushing	VITON	PTFE	PTFE
6	Sealing Ring	Rubber	NBR	NBR

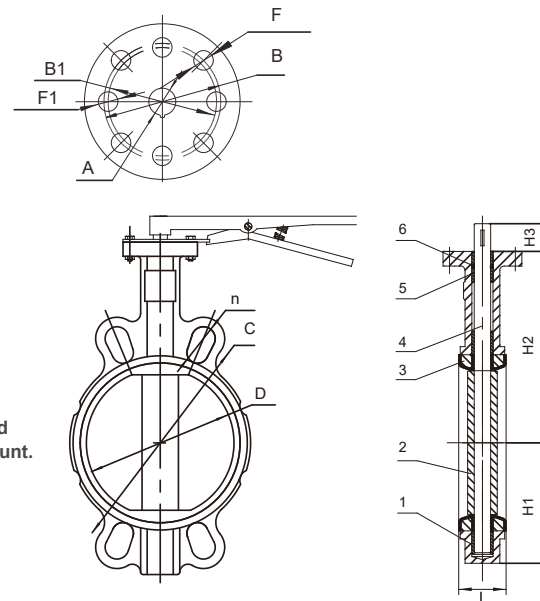

\* Suffix - L for operation by lever, - G for operation by worm gear, - O for polished rod  
 \* An electric or pneumatic actuator may be mounted to match an ISO5211-based mount.  
 Please refer to the TALOAR Butterfly Valve Torque Table in Page 50.

### Dimensions

mm	50	65	80	100	125	150	200	250	300
In	2	2½	3	4	5	6	8	10	20
L	46	49	49	55	58	59	64	71.5	81
H1	68	74	92	107	121	136	171	200	239
H2	122	133	143	164	185	196	225	267	311
H3	30	30	30	30	30	30	36	36	36
D	52.7	64.4	78.8	104	123.3	156	202.3	250.3	301.3
EN	C	125	145	160	180	210	240	295	355
	n-d	4-18	4-18	8-18	8-18	8-18	8-23	12-23	12-27
AN	C	120.5	139.5	152.5	190.5	216	241.5	298.5	362
	n-d	4-19	4-19	4-19	8-19	8-22	8-22	8-22	12-25
B	57.15	57.15	57.15	70	70	70	88.9	88.9	107.95
B1	50	50	50	70	70	70	88.9	88.9	107.95
F	7	7	7	9	9	9	14	14	14
F1	7	7	7	9	9	9	14	14	14

Note: Steam services are not recommended. For valves over 6" , operation by the worm gear is suggested.

### Stainless Steel Butterfly Valves PN16/235PSI/Class125

**Wafer Style**  
**Design to API609 and MSS SP-67**  
**Flange Dimension to EN1092-2, ANSI B16.1 Class 125**

Sealing Performance	
EPDM	-20°C- 120°C
NBR	-10°C- 80°C
VITON	-20°C- 150°C

Hydraulic Pressure Test	
Body	2.4Mpa/24Bar
Seat	1.76Mpa/17.6Bar



**HB350-G/O**  
14" – 24"

#### Materials List

No	Part	Specification	BS EN	ASTM
1	Body	Stainless Steel	BS970 316 BS970 304	CF8M CF8
2	Disc	Stainless Steel	BS970 316 BS970 304	CF8M CF8
3	Seat	EPDM NBR VITON	EPDM NBR VITON	EPDM NBR VITON
4	Shaft	Stainless Steel	BSEN 10088-1	A582 420
5	Bushing	Composite Material	PTFE&Bronze	PTFE&Bronze
6	Sealing Ring	Rubber	NBR	NBR

\* Suffix - G for operation by worm gear, - O for polished rod  
 \* An electric or pneumatic actuator may be mounted to match an ISO5211-based mount.  
 Please refer to the TALOAR Butterfly Valve Torque Table in Page 50.

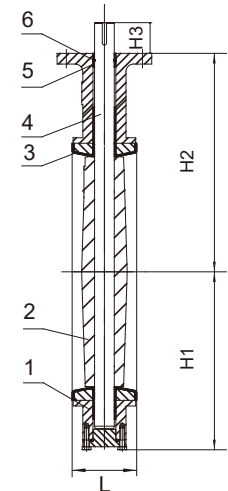
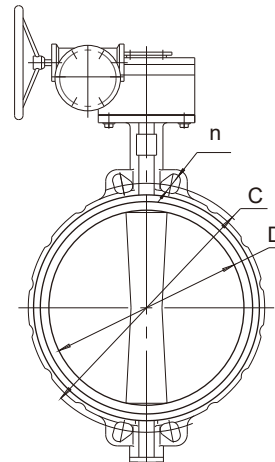

#### Dimensions

mm	350	400	450	500	600	
In	14	16	18	20	24	
L	79.5	90	109	135	157	
H1	262	302	326	360	444	
H2	368	400	422	480	562	
H3	45	51	51	64	70	
D	333.3	389.6	439.9	491.6	592.6	
EN	C	470	525	585	650	770
	n-d	16-27	16-30	20-30	20-33	20-36
AN	C	476	539.5	578	635	749.5
	n-d	12-29	16-29	16-32	20-32	20-35
A	31.8	33.3	38	41.15	50.65	
B	107.95	158.75	158.75	158.75	215.9	
F	15	20.6	20.6	20.6	22.2	

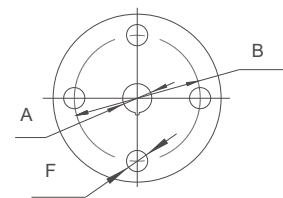

Note: Steam services are not recommended.

### Ductile Iron Butterfly Valves PN16/235PSI/Class125

Lug Style, Pin-Free Valve Shaft, Seal-Line Seat  
Design to BS5155 and MSS SP-67  
Flange Dimension to EN1092-2, ANSI B16.1 Class 125



**HB960-L/G/O**  
2" - 12"

Sealing Performance	
EPDM	-20°C- 120°C
NBR	-10°C- 80°C
VITON	-20°C- 150°C

Hydraulic Pressure Test	
Body	2.4Mpa/24Bar
Seat	1.76Mpa/17.6Bar

#### Materials List

No	Part	Specification	BS EN	ASTM
1	Body	Ductile Iron	BSEN 1563	A536 65-45-12
2	Bottom Stem	Stainless Steel	BSEN 10088-1	A582 420
3	O-Ring	NBR	NBR	NBR
4	Seat	EPDM	EPDM	EPDM
		NBR	NBR	NBR
		VITON	VITON	VITON
5	Disc	Ductile Iron	BSEN 1563	A536 65-45-12
		Stainless Steel	BS970 304S15	CF8
		Aluminum Bronze	1400AB2	B148 Ay 954
6	Upper Stem	Stainless Steel	BSEN 10088-1	A582 420
7	Bushing	Composite Material	PTFE&Bronze	PTFE&Bronze
8	Screw	Steel	BSEN 10087	A307
9	Retaining Cap	Steel	BSEN 10087	A307

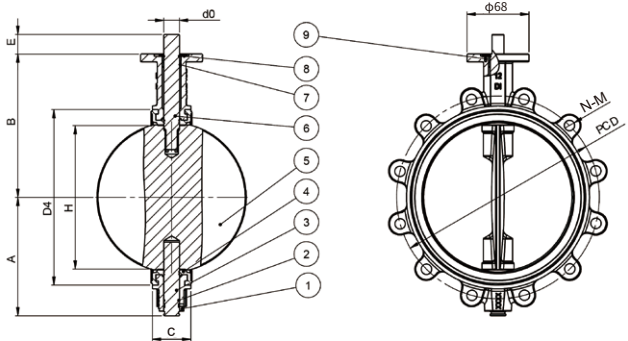
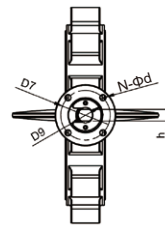

\* Suffix - L for operation by lever, - G for operation by worm gear, - O for polished rod  
\* An electric or pneumatic actuator may be mounted to match an ISO5211-based mount.  
Please refer to the TALOAR Butterfly Valve Torque Table in Page 50.

#### Dimensions-Weights

mm	50	65	80	100	125	150	200	250	300
In	2	2½	3	4	5	6	8	10	12
A	78	90	99	120	134	142	178	203	240
B	120	137	145	160	175	189	220	250	290
C	43	46	46	52	56	56	62	68	78
E	30	30	30	30	30	30	40	40	40
H	40	43	60.3	87.3	106.5	142.3	193.2	242.2	290.2
D4	83	95.5	138.0	139.0	167.0	194.0	247.6	300.0	352.0
d0	12.60	12.60	12.60	15.77	18.92	18.92	22.10	28.45	31.60
PCD	125	145	160	180	210	240	295	355	410
N-M	4-M16	4-M16	8-M16	8-M16	8-M16	8-M20	12-M20	12-M24	12-M24
h	9	9	9	11	14	14	17	22	24
D6	90	90	90	90	90	90	125	125	125
D7	70	70	70	70	70	70	102	102	102
D9	55	55	55	55	55	55	70	70	70
n-φd	4-10	4-10	4-10	4-10	4-10	4-10	4-12	4-12	4-12
ISO5211	F07	F07	F07	F07	F07	F07	F10	F10	F10
Weight	Lbs	10	12	14	17	22	32	52	89
	Kg	5	5	6	8	10	15	24	40

### Ductile Iron Butterfly Valves PN16/235PSI/Class125

Lug Style, Pin-Free Valve Shaft, Seal-Line Seat  
Design to BS5155 and MSS SP-67  
Flange Dimension to EN1092-2, ANSI B16.1 Class 125



**HB960-G/O**  
14" - 32"

Sealing Performance	
EPDM	-20°C- 120°C
NBR	-10°C- 80°C
VITON	-20°C- 150°C

Hydraulic Pressure Test	
Body	2.4Mpa/24Bar
Seat	1.76Mpa/17.6Bar

#### Materials List

No	Part	Specification	BS EN	ASTM
1	Body	Ductile Iron	BSEN 1563	A536 65-45-12
2	Bottom Stem	Stainless Steel	BSEN 10088-1	A582 420
3	Disc	Ductile Iron	BSEN 1563	A536 65-45-12
		Stainless Steel Aluminum Bronze	BS970 304S15 1400AB2	CF8 B148 Ay 954
4	Upper Stem	Stainless Steel	BSEN 10088-1	A582 420
5	Seat	EPDM	EPDM	EPDM
		NBR	NBR	NBR
		VITON	VITON	VITON
6	Bushing	Composite Material	PTFE&Bronze	PTFE&Bronze
7	Retaining Cap	Steel	BSEN 10087	A307
8	Gearbox	Ductile Iron	BSEN 1563	A536 65-45-12

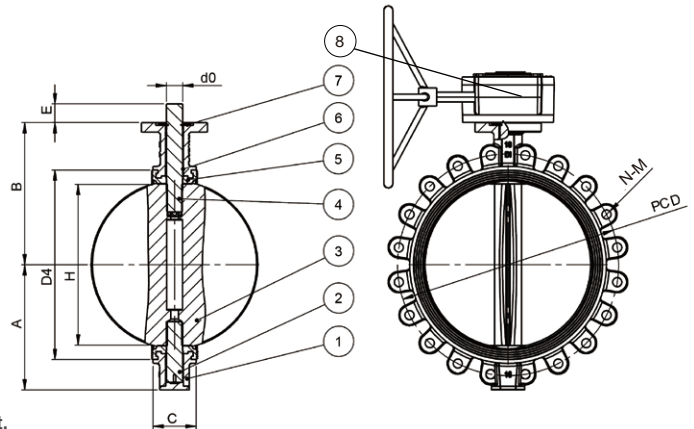
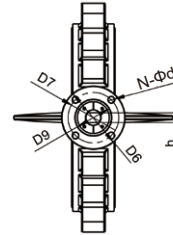

\* Suffix - G for operation by worm gear, - O for polished rod  
\* An electric or pneumatic actuator may be mounted to match an ISO5211-based mount.  
Please refer to the TALoar Butterfly Valve Torque Table in Page 50.

#### Dimensions-Weights

mm	350	400	450	500	600	700	800
In	14	16	18	20	24	28	32
A	272	296	330	360	447	517	567
B	320	340	375	430	564	616	666
C	78	102	114	127	154	165	190
E	45	50	50	60	60	80	80
H	322.6	374.4	424.2	473.2	572.0	673.0	774.0
D4	404	450	500	555	660	775	875
d0	31.60	37.95	42.86	45.72	53.98	63.35	63.35
h	24	27	27	32	36	Key18*2	Key18*2
PCD	470	525	585	650	770	840	950
N-M	16-M24	16-M27	20-M27	20-M30	20-M33	24-M33	24-M36
D6	125	175	175	175	210	300	300
D7	102	140	140	140	165	254	254
D9	70	100	100	100	130	130	130
n-Ød	4-12	4-18	4-18	4-18	4-23	8-18	8-18
ISO5211	F10	F14	F14	F14	F16	F25	F25
Weight	Lbs	137	216	262	392	750	926
	Kg	62	98	119	178	340	420

Note: Steam services are not recommended.

### Ductile Iron Butterfly Valves PN16/235PSI/Class125

Dual-Flanged Style, Pin-Free Valve Shaft, Vulcanized Rubber Seat  
Design to BS5155 and MSS SP-67  
Flange Dimension EN1092-2, ANSI B16.1 Class 125



**HB970-L/G/O**  
2" - 12"

Sealing Performance	
EPDM	-20°C- 120°C
NBR	-10°C- 80°C

Hydraulic Pressure Test	
Body	2.4Mpa/24Bar
Seat	1.76Mpa/17.6Bar

#### Materials List

No	Part	Specification	BS EN	ASTM
1	Body	Ductile Iron	BSEN 1563	A536 65-45-12
2	O-Ring	Rubber	NBR	NBR
3	Bottom Stem	Stainless Steel	BSEN 10088-1	A582 420
4	Disc	Ductile Iron	BSEN 1563	A536 65-45-12
		Stainless Steel	BS970 304S15	CF8
		Aluminum Bronze	1400AB2	B148 Ay 954
5	Seat	EPDM	EPDM	EPDM
		NBR	NBR	NBR
6	Upper Stem	Stainless Steel	BSEN 10088-1	A582 420
7	Shaft Sleeve	PTFE	PTFE	PTFE
8	Retaining Cap	Steel	BSEN 10087	A307

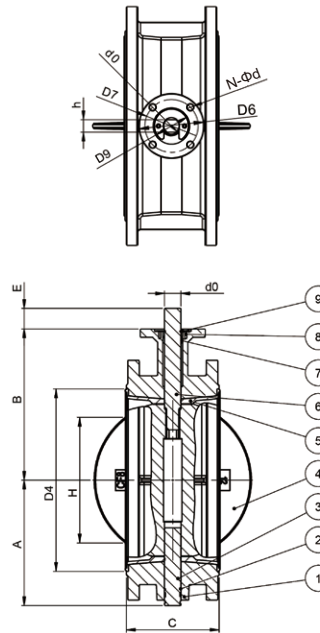

\* Suffix - L for operation by lever, - G for operation by worm gear, - O for polished rod  
\* An electric or pneumatic actuator may be mounted to match an ISO5211-based mount.  
Please refer to the TALOAR Butterfly Valve Torque Table in Page 50.

#### Dimensions-Weights

mm	50	65	80	100	125	150	200	250	300
In	2	2½	3	4	5	6	8	10	12
A	78	90	99	120	134	142	178	203	240
B	120	137	145	160	175	189	220	250	290
C	108	112	114	127	140	140	152	165	178
E	30	30	30	30	30	30	40	40	40
H	NA	NA	NA	NA	NA	70	130	187	242
D4	89	106	120	144	170	197	252	305	350
d0	12.60	12.60	12.60	15.77	18.92	18.92	22.10	28.45	31.60
PCD	125	145	160	180	210	240	295	355	410
N-d1	4-19	4-19	8-19	8-19	8-19	8-23	12-23	12-28	12-28
h	9	9	9	11	14	14	17	22	24
D6	90	90	90	90	90	90	125	125	125
D7	70	70	70	70	70	70	102	102	102
D9	55	55	55	55	55	55	70	70	70
n-Ød	4-10	4-10	4-10	4-10	4-10	4-10	4-12	4-12	4-12
ISO5211	F07	F07	F07	F07	F07	F07	F10	F10	F10
Weight	Lbs	17	20	22	27	32	39	70	133
	Kg	8	9	10	12	15	18	32	60

\* Applicable to cold/hot water systems of air-conditioners, municipal water supply systems, water treatment facilities and industrial plants.

### Ductile Iron Butterfly Valves PN16/235PSI/Class125

Dual-Flanged Style, Pin-Free Valve Shaft, Vulcanized Rubber Seat  
Design to BS5155 and MSS SP-67  
Flange Dimension EN1092-2, ANSI B16.1 Class 125



**HB970-G/O**  
14" - 32"

Sealing Performance	
EPDM	-20°C- 120°C
NBR	-10°C- 80°C

Hydraulic Pressure Test	
Body	2.4Mpa/24Bar
Seat	1.76Mpa/17.6Bar

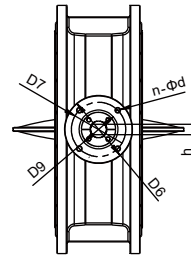

#### Materials List

No	Part	Specification	BS EN	ASTM
1	Body	Ductile Iron	BSEN 1563	A536 65-45-12
2	Bottom Stem	Stainless Steel	BSEN 10088-1	A582 420
3	Disc	Ductile Iron	BSEN 1563	A536 65-45-12
		Stainless Steel	BS970 304S15	CF8
		Aluminum Bronze	1400AB2	B148 Ay 954
4	Upper Stem	Stainless Steel	BSEN 10088-1	A582 420
5	Seat	EPDM	EPDM	EPDM
		NBR	NBR	NBR
6	Shaft Sleeve	PTFE	PTFE	PTFE
7	Retaining Cap	Steel	BSEN 10087	A307
8	Worm Gear Box	Ductile Iron	BSEN 1563	A536 65-45-12

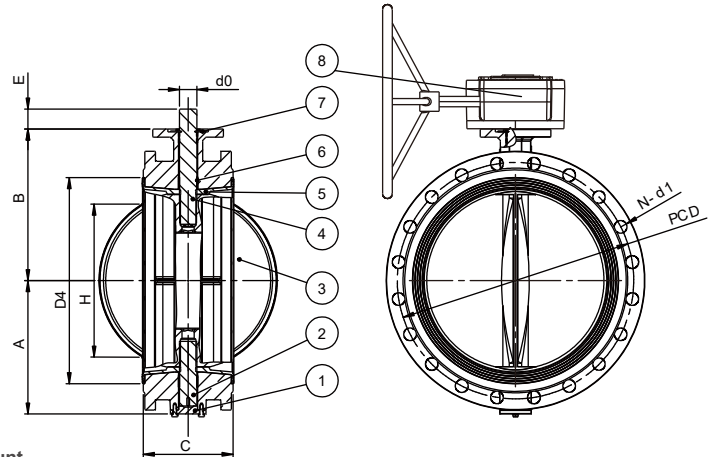

\* Suffix - G for operation by worm gear, - O for polished rod  
\* An electric or pneumatic actuator may be mounted to match an ISO5211-based mount.  
Please refer to the TALOAR Butterfly Valve Torque Table in Page 50.

#### Dimensions-Weights

mm	350	400	450	500	600	700	800
In	14	16	18	20	24	28	32
A	270	305	330	360	420	517	567
B	330	365	400	445	505	616	666
C	190	216	222	229	267	292	318
E	45	50	50	65	65	80	80
H	274	330	378	435	535	635	740
D4	416	460	510	560	660	770	880
d0	31.60	38.1	42.8	45.8	53.98	63.35	63.35
h	24	27	27	32	36	Key18*2	Key18*2
PCD	470	525	585	650	770	840	950
N-d1	16-28	16-31	20-31	20-34	20-37	24-37	24-40
D6	125	175	175	175	210	300	300
D7	102	140	140	140	165	254	254
D9	70	100	100	100	130	130	130
n-φd	4-12	4-18	4-18	4-18	4-23	8-18	8-18
ISO5211	F10	F14	F14	F14	F16	F25	F25
Weight	Lbs	172	251	304	445	699	926
	Kg	78	114	138	202	317	420

\* Applicable to cold/hot water systems of air-conditioners, municipal water supply systems, water treatment facilities and industrial plants.

### Electric Butterfly Valves

PN16/235PSI/Class125

220V/380V · Multi-stage Aluminum Alloy Housing  
 Asynchronous Motor · Precision Gear  
 Moisture-proof Heating Resistor · Epoxy Resin Coating  
 90° Rotation · IP67 Protection  
 Wafer Style, Flange Dimension EN1092-2, ANSI B16.1 Class 125



**HB950/S-EH/ RH**

2" - 12"

Sealing Performance	
EPDM	-20°C- 120°C
NBR	-10°C- 80°C
VITON	-20°C- 150°C

Hydraulic Pressure Test	
Body	2.4Mpa/24Bar
Seat	1.76Mpa/17.6Bar

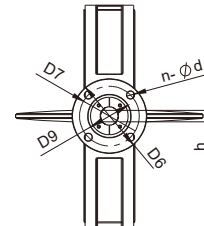

#### Materials List

No	Part	Specification	BS EN	ASTM
1	Body	Ductile Iron	BSEN 1563	A536 65-45-12
2	Bottom Stem	Stainless Steel	BSEN 10088-1	A582 420
3	O-Ring	NBR	NBR	NBR
4	Seat	EPDM	EPDM	EPDM
		NBR	NBR	NBR
		VITON	VITON	VITON
5	Disc	Ductile Iron	BSEN 1563	A536 65-45-12
		Stainless Steel	BS970 304S15	CF8
		Aluminum Bronze	1400AB2	B148 Ay 954
6	Upper Stem	Stainless Steel	BSEN 10088-1	A582 420
7	Bushing	Composite Material	PTFE&Bronze	PTFE&Bronze
8	Screw	Steel	BSEN 10087	A307
9	Electric Actuators	Other		

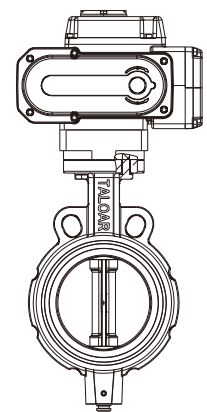
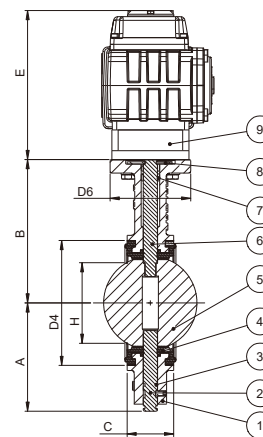

\* Figure number - EH for ON/OFF control, - RH for regulating control.  
 Please specify when ordering.

#### Dimensions-Weights

mm	50	65	80	100	125	150	200	250	300	
In	2	2½	3	4	5	6	8	10	12	
A	78	90	99	120	134	142	178	203	240	
B	120	137	145	160	175	189	220	250	290	
C	43	46	46	52	56	56	62	68	78	
E	115	115	115	115	120	120	142	142	142	
H	23.9	39.5	60.3	87.3	106.5	142.3	193.2	242.2	290.2	
D4	83	96	138	139	167	194	248	300	352	
h	9	9	9	11	14	14	17	22	24	
D6	90	90	90	90	90	90	125	125	125	
D7	70	70	70	70	70	70	102	102	102	
D9	55	55	55	55	55	55	70	70	70	
n-φd	4-10	4-10	4-10	4-10	4-10	4-10	4-12	4-12	4-12	
ISO5211	F07	F07	F07	F07	F07	F07	F10	F10	F10	
Weight	Lbs	10.6	12.1	13.0	21.4	24.9	39.2	52.3	63.7	129.7
	Kg	4.8	5.5	5.9	9.7	11.3	17.8	23.7	28.9	58.8

Note: Steam services are not recommended.

### Electric Butterfly Valves

PN16/235PSI/Class125

220V/380V · Multi-stage Aluminum Alloy Housing  
 Asynchronous Motor · Precision Gear  
 Moisture-proof Heating Resistor · Epoxy Resin Coating  
 90° Rotation · IP67 Protection  
 Wafer Style, Flange Dimension EN1092-2, ANSI B16.1 Class 125



**HB950/S-EH/ RH**

14" – 24"

Sealing Performance	
EPDM	-20°C- 120°C
NBR	-10°C- 80°C
VITON	-20°C- 150°C

Hydraulic Pressure Test	
Body	2.4Mpa/24Bar
Seat	1.76Mpa/17.6Bar

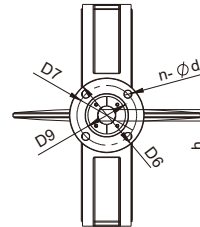

#### Materials List

No	Part	Specification	BS EN	ASTM
1	Body	Ductile Iron	BSEN 1563	A536 65-45-12
2	Bottom Stem	Stainless Steel	BSEN 10088-1	A582 420
3	Disc	Ductile Iron	BSEN 1563	A536 65-45-12
		Stainless Steel	BS970 304S15	CF8
		Aluminum Bronze	1400AB2	B148 Ay 954
4	Upper Stem	Stainless Steel	BSEN 10088-1	A582 420
5	Seat	EPDM	EPDM	EPDM
		NBR	NBR	NBR
		VITON	VITON	VITON
6	Bushing	Composite Material	PTFE&Bronze	PTFE&Bronze
7	Retaining Cap	Steel	BSEN 10087	A307
8	Electric Actuators	Other		

\* Figure number - EH for ON/OFF control, - RH for regulating control.  
 Please specify when ordering.

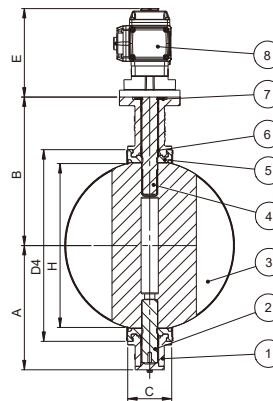

#### Dimensions-Weights

mm	350	400	450	500	600	
In	14	16	18	20	24	
A	272	296	330	360	447	
B	320	340	375	430	564	
C	78	102	114	127	154	
E	158	158	158	158	NA	
H	322.6	374.4	424.2	473.2	572.0	
D4	404	450	500	555	660	
h	24	27	27	32	36	
D6	125	175	175	175	210	
D7	102	140	140	140	165	
D9	70	100	100	100	130	
n-φd	4-12	4-18	4-18	4-18	4-23	
ISO5211	F10	F14	F14	F14	F16	
Weight	Lbs	132	163	190	256	NA
	Kg	60	74	86	116	NA

Note: Steam services are not recommended.

### Electric Butterfly Valves

#### PN16/235PSI/Class125

220V/380V · Multi-stage Alloy Steel Reduction Gears and Worm  
 Over-torque Protection · Moisture-proof Heating Resistor  
 Epoxy Resin Coating · 90° Rotation · IP67 Protection  
 Threaded Hole Lug Style,  
 Flange Dimension EN1092-2, ANSI B16.1 Class 125

Sealing Performance	
EPDM	-20°C- 120°C
NBR	-10°C- 80°C
VITON	-20°C- 150°C

Hydraulic Pressure Test	
Body	2.4Mpa/24Bar
Seat	1.76Mpa/17.6Bar

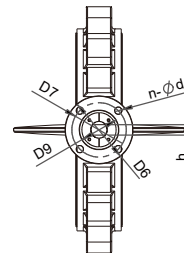

**HB960/S-ET/ RM**

2" - 12"

#### Materials List

No	Part	Specification	BS EN	ASTM
1	Body	Ductile Iron	BSEN 1563	A536 65-45-12
2	Bottom Stem	Stainless Steel	BSEN 10088-1	A582 420
3	O-Ring	NBR	NBR	NBR
4	Seat	EPDM	EPDM	EPDM
		NBR	NBR	NBR
		VITON	VITON	VITON
5	Disc	Ductile Iron	BSEN 1563	A536 65-45-12
		Stainless Steel	BS970 304S15	CF8
		Aluminum Bronze	1400AB2	B148 Ay 954
6	Upper Stem	Stainless Steel	BSEN 10088-1	A582 420
7	Bushing	Composite Material	PTFE&Bronze	PTFE&Bronze
8	Screw	Steel	BSEN 10087	A307
9	Electric Actuators	Other		

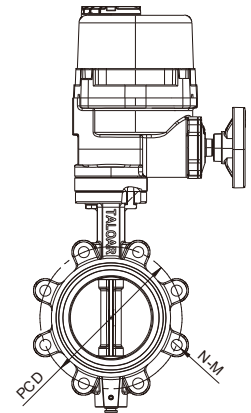
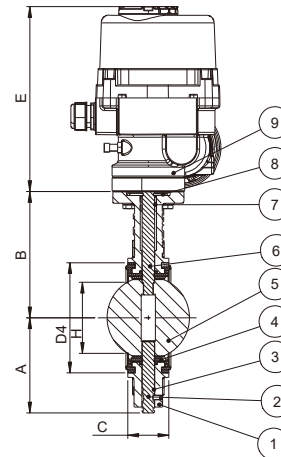

\* Figure number - ET for ON/OFF control, - RM for regulating control.  
 Please specify when ordering.

\* For details concerning actuator dimensions and models, please refer to Pages 52-53.

#### Dimensions-Weights

mm	50	65	80	100	125	150	200	250	300
In	2	2½	3	4	5	6	8	10	12
A	78	90	99	120	134	142	178	203	240
B	120	137	145	160	175	189	220	250	290
C	43	46	46	52	56	56	62	68	78
E	235	235	235	275	275	275	330	330	365
H	23.9	39.5	60.3	87.3	106.5	142.3	193.2	242.2	290.2
D4	83	95.5	138.0	139.0	167.0	194.0	247.6	300.0	352.0
PCD	125	145	160	180	210	240	295	355	410
N-M	4-M16	4-M16	8-M16	8-M16	8-M16	8-M20	12-M20	12-M24	12-M24
h	9	9	9	11	14	14	17	22	24
D6	90	90	90	90	90	90	125	125	125
D7	70	70	70	70	70	70	102	102	102
D9	55	55	55	55	55	55	70	70	70
n-φd	4-10	4-10	4-10	4-10	4-10	4-10	4-12	4-12	4-12
ISO5211	F07	F07	F07	F07	F07	F07	F10	F10	F10
Weight	Lbs	7.5	8.6	11	14.6	19	30.4	52.9	77.2
	Kg	3.4	3.9	5	6.6	8.6	13.8	24	35

Note: Steam services are not recommended.

### Electric Butterfly Valves

#### PN16/235PSI/Class125

220V/380V · Multi-stage Alloy Steel Reduction Gears and Worm  
 Over-torque Protection · Moisture-proof Heating Resistor  
 Epoxy Resin Coating · 90° Rotation · IP67 Protection  
 Threaded Hole Lug Style,  
 Flange Dimension EN1092-2, ANSI B16.1 Class 125



**HB960/S-ET/ RM**

14" - 32"

Sealing Performance	
EPDM	-20°C- 120°C
NBR	-10°C- 80°C
VITON	-20°C- 150°C

Hydraulic Pressure Test	
Body	2.4Mpa/24Bar
Seat	1.76Mpa/17.6Bar

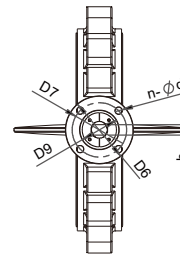

#### Materials List

No	Part	Specification	BS EN	ASTM
1	Body	Ductile Iron	BSEN 1563	A536 65-45-12
2	Bottom Stem	Stainless Steel	BSEN 10088-1	A582 420
3	Disc	Ductile Iron	BSEN 1563	A536 65-45-12
		Stainless Steel	BS970 304S15	CF8
		Aluminum Bronze	1400AB2	B148 Ay 954
4	Upper Stem	Stainless Steel	BSEN 10088-1	A582 420
5	Seat	EPDM	EPDM	EPDM
		NBR	NBR	NBR
		VITON	VITON	VITON
6	Bushing	Composite Material	PTFE&Bronze	PTFE&Bronze
7	Retaining Cap	Steel	BSEN 10087	A307
8	Electric Actuators	Other		

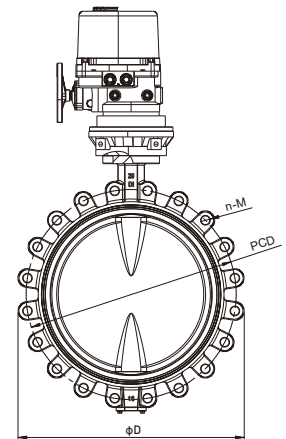
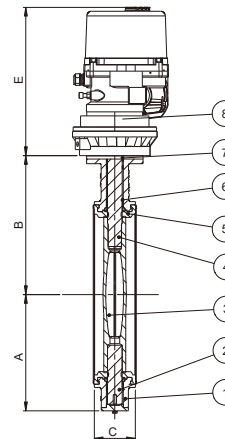

\* Figure number - ET for ON/OFF control, - RM for regulating control.

Please specify when ordering.

\* For details concerning actuator dimensions and models, please refer to Pages 52-53.

#### Dimensions-Weights

mm	350	400	450	500	600	700	800	
In	14	16	18	20	24	28	32	
A	272	296	330	360	447	517	567	
B	320	340	375	430	564	616	666	
C	78	102	114	127	154	165	190	
E	353	353	475	475	390	500	545	
φD	520	580	640	715	840	910	1025	
h	24	27	27	32	36	key18*2	key18*2	
PCD	470	525	585	650	770	840	950	
N-M	16-M24	16-M27	20-M27	20-M30	20-M33	24-M33	24-M36	
D6	125	175	175	175	210	300	300	
D7	102	140	140	140	165	254	254	
D9	70	100	100	100	130	130	130	
n-φd	4-12	4-18	4-18	4-18	4-22	4-18	8-18	
ISO5211	F10	F14	F14	F14	F16	F25	F25	
Weight	Lbs	137	216	262	393	419	628	834
	Kg	62	98	119	178	190	285	378

Note: Steam services are not recommended.

### Electric Butterfly Valves

PN16/235PSI/Class125

220V/ 380V • Multi-stage Aluminum Alloy Housing  
 Asynchronous Motor • Precision Gear  
 Moisture-proof Heating Resistor • Epoxy Resin Coating  
 90° Rotation • IP67 Protection  
 Lug Style, Flange Dimension EN1092-2, ANSI B16.1 Class 125



**HB960/S-EH/ RH**  
 2" - 12"

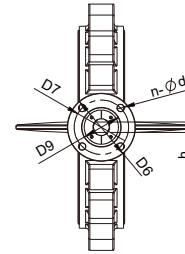

Sealing Performance	
EPDM	-20°C- 120°C
NBR	-10°C- 80°C
VITON	-20°C- 150°C

Hydraulic Pressure Test	
Body	2.4Mpa/24Bar
Seat	1.76Mpa/17.6Bar

#### Materials List

No	Part	Specification	BS EN	ASTM
1	Body	Ductile Iron	BSEN 1563	A536 65-45-12
2	Bottom Stem	Stainless Steel	BSEN 10088-1	A582 420
3	Disc	Ductile Iron	BSEN 1563	A536 65-45-12
		Stainless Steel	BS970 304S15	CF8
		Aluminum Bronze	1400AB2	B148 Ay 954
4	Upper Stem	Stainless Steel	BSEN 10088-1	A582 420
5	Seat	EPDM	EPDM	EPDM
		NBR	NBR	NBR
		VITON	VITON	VITON
6	Bushing	Composite Material	PTFE&Bronze	PTFE&Bronze
7	Retaining Cap	Steel	BSEN 10087	A307
8	Electric Actuators	Other		

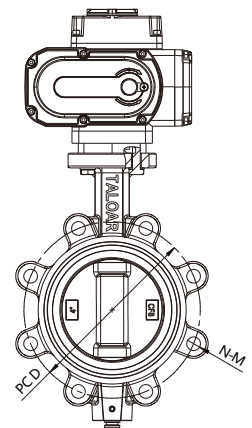
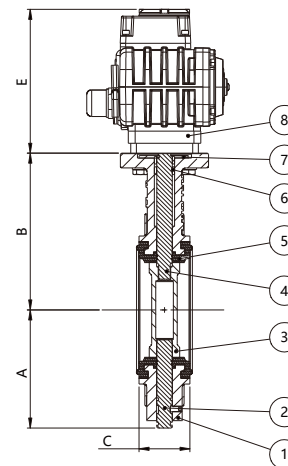

\* Figure number - EH for ON/OFF control, - RH for regulating control,  
 4 ~ 20mA or 0 ~ 10V, Please specify when ordering.

#### Dimensions

mm	50	65	80	100	125	150	200	250	300
In	2	2½	3	4	5	6	8	10	12
A	78	90	99	120	134	142	178	203	240
B	120	137	145	160	175	189	220	250	290
C	43	46	46	52	56	56	60	68	78
E	150	150	150	168	168	168	204	204	240
PCD	125	145	160	180	210	240	295	355	410
N-M	4-M16	4-M16	8-M16	8-M16	8-M16	8-M20	12-M20	12-M24	12-M24
h	9	9	9	11	14	14	17	22	24
D6	90	90	90	90	90	90	125	125	125
D7	70	70	70	70	70	70	102	102	102
D9	55	55	55	55	55	55	70	70	70
n-φd	4-10	4-10	4-10	4-10	4-10	4-10	4-12	4-12	4-12
ISO5211	F07	F07	F07	F07	F07	F07	F10	F10	F10

Note: Steam services are not recommended.

### Electric Butterfly Valves

PN16/235PSI/Class125

220V/ 380V • Multi-stage Aluminum Alloy Housing

Asynchronous Motor • Precision Gear

Moisture-proof Heating Resistor • Epoxy Resin Coating

90° Rotation • IP67 Protection

Lug Style, Flange Dimension EN1092-2, ANSI B16.1 Class 125

Sealing Performance	
EPDM	-20°C- 120°C
NBR	-10°C- 80°C
VITON	-20°C- 150°C

Hydraulic Pressure Test	
Body	2.4Mpa/24Bar
Seat	1.76Mpa/17.6Bar

#### Materials List

No	Part	Specification	BS EN	ASTM
1	Body	Ductile Iron	BSEN 1563	A536 65-45-12
2	Bottom Stem	Stainless Steel	BSEN 10088-1	A582 420
3	Disc	Ductile Iron	BSEN 1563	A536 65-45-12
		Stainless Steel	BS970 304S15	CF8
		Aluminum Bronze	1400AB2	B148 Ay 954
4	Upper Stem	Stainless Steel	BSEN 10088-1	A582 420
5	Seat	EPDM	EPDM	EPDM
		NBR	NBR	NBR
		VITON	VITON	VITON
6	Bushing	Composite Material	PTFE&Bronze	PTFE&Bronze
7	Retaining Cap	Steel	BSEN 10087	A307
8	Electric Actuators	Other		

\* Figure number - EH for ON/OFF control, - RH for regulating control,  
4~20mA or 0~10V, Please specify when ordering.

#### Dimensions

mm	350	400	450	500
In	14	16	18	20
A	272	296	340	364
B	320	340	398	430
C	78	102	114	127
E	240	258	258	258
PCD	470	525	585	650
N-M	16-M24	16-M27	20-M27	20-M30
h	24	27	27	32
D6	125	175	175	175
D7	102	140	140	140
D9	70	100	100	100
n-Φd	4-12	4-18	4-18	4-18
ISO5211	F10	F14	F14	F14

Note: Steam services are not recommended.

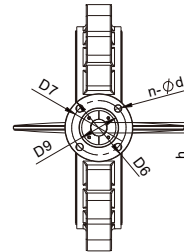

HB960/S-EH/ RH

14" - 20"

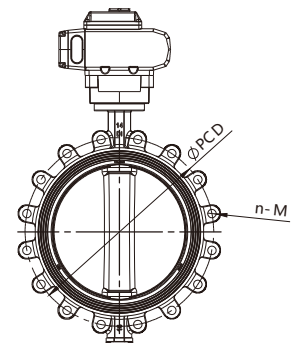
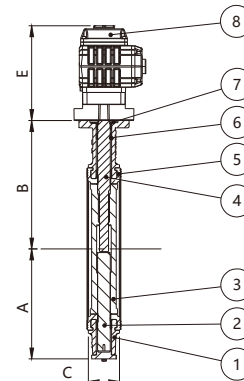

### Electric Butterfly Valves

PN16/235PSI/Class125

220V/380V · Multi-stage Alloy Steel Reduction Gears and Worm  
 Over-torque Protection · Moisture-proof Heating Resistor  
 Epoxy Resin Coating · 90° Rotation · IP67 Protection  
 Double Flange Type,  
 Flange Dimension EN1092-2, ANSI B16.1 Class 125



**HB970/S-ET/ RM**  
 2" - 12"

Sealing Performance	
EPDM	-20°C- 120°C
NBR	-10°C- 80°C
VITON	-20°C- 150°C

Hydraulic Pressure Test	
Body	2.4Mpa/24Bar
Seat	1.76Mpa/17.6Bar

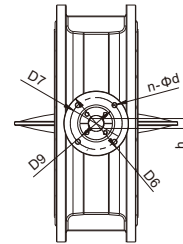

#### Materials List

No	Part	Specification	BS EN	ASTM
1	Body	Ductile Iron	BSEN 1563	A536 65-45-12
2	Bottom Stem	Stainless Steel	BSEN 10088-1	A582 420
3	O-Ring	NBR	NBR	NBR
4	Seat	EPDM	EPDM	EPDM
		NBR	NBR	NBR
		VITON	VITON	VITON
5	Disc	Ductile Iron	BSEN 1563	A536 65-45-12
		Stainless Steel	BS970 304S15	CF8
		Aluminum Bronze	1400AB2	B148 Ay 954
6	Upper Stem	Stainless Steel	BSEN 10088-1	A582 420
7	Bushing	Composite Material	PTFE&Bronze	PTFE&Bronze
8	Screw	Steel	BSEN 10087	A307
9	Electric Actuators	Other		

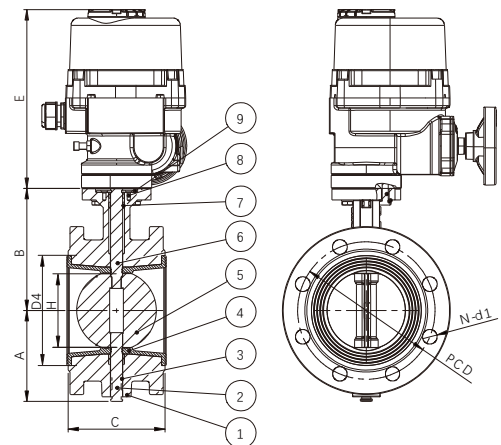

\* Figure number - ET for ON/OFF control, - RM for regulating control.  
 Please specify when ordering.

\* For details concerning actuator dimensions and models, please refer to Pages 52-53.

#### Dimensions-Weights

mm	50	65	80	100	125	150	200	250	300
In	2	2½	3	4	5	6	8	10	12
A	78	90	99	120	134	142	178	203	240
B	120	137	145	160	175	189	220	250	290
C	108	112	114	127	140	140	152	165	178
E	115	115	115	115	120	120	142	142	142
H	23.9	39.5	60.3	87.3	106.5	142.3	193.2	242.2	290.2
D4	89	106	120	144	170	197	252	305	350
PCD	125	145	160	180	210	240	295	355	410
N-d1	4-19	4-19	8-19	8-19	8-19	8-23	12-23	12-28	12-28
h	9	9	9	11	14	14	17	22	24
D6	90	90	90	90	90	90	125	125	125
D7	70	70	70	70	70	70	102	102	102
D9	55	55	55	55	55	55	70	70	70
n-Φd	4-10	4-10	4-10	4-10	4-10	4-10	4-12	4-12	4-12
ISO5211	F07	F07	F07	F07	F07	F07	F10	F10	F10
Weight	Lbs	14.1	17.2	20.3	26.5	32.6	65.7	78.3	110.9
	Kg	6.4	7.8	9.2	12	14.8	18	29.8	50.3

Note: Steam services are not recommended.

### Electric Butterfly Valves PN16/235PSI/Class125

220V/380V · Multi-stage Alloy Steel Reduction Gears and Worm  
Over-torque Protection · Moisture-proof Heating Resistor  
Epoxy Resin Coating · 90° Rotation · IP67 Protection  
Double Flange Type,  
Flange Dimension EN1092-2, ANSI B16.1 Class 125



**HB970/S-ET/ RM**  
14" - 32"

Sealing Performance	
EPDM	-20°C- 120°C
NBR	-10°C- 80°C
VITON	-20°C- 150°C

Hydraulic Pressure Test	
Body	2.4Mpa/24Bar
Seat	1.76Mpa/17.6Bar

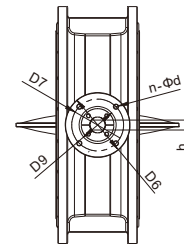

#### Materials List

No	Part	Specification	BS EN	ASTM
1	Body	Ductile Iron	BSEN 1563	A536 65-45-12
2	Bottom Stem	Stainless Steel	BSEN 10088-1	A582 420
3	Disc	Ductile Iron	BSEN 1563	A536 65-45-12
		Stainless Steel	BS970 304S15	CF8
		Aluminum Bronze	1400AB2	B148 Ay 954
4	Upper Stem	Stainless Steel	BSEN 10088-1	A582 420
5	Seat	EPDM	EPDM	EPDM
		NBR	NBR	NBR
		VITON	VITON	VITON
6	Bushing	Composite Material	PTFE&Bronze	PTFE&Bronze
7	Retaining Cap	Steel	BSEN 10087	A307
8	Electric Actuators	Other		

\* Figure number - ET for ON/OFF control, - RM for regulating control.  
Please specify when ordering.

\* For details concerning actuator dimensions and models, please refer to Pages 52-53.

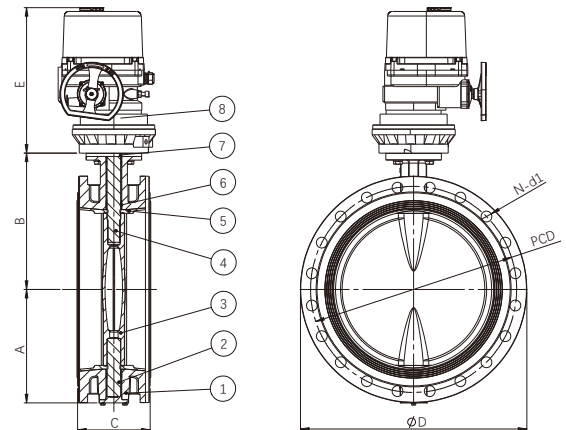

#### Dimensions-Weights

mm	350	400	450	500	600	700	800	
In	14	16	18	20	24	28	32	
A	270	305	330	350	420	517	567	
B	330	365	400	445	505	616	666	
C	190	216	222	229	267	292	318	
E	353	353	475	475	390	475	545	
ΦD	520	580	640	715	840	910	1025	
h	24	27	27	32	36	Key18*2	Key18*2	
PCD	470	525	585	650	770	840	950	
N-d1	16-28	16-31	20-31	20-34	20-37	24-37	24-40	
D6	125	175	175	175	210	300	360	
D7	102	140	140	140	165	254	254	
D9	70	100	100	100	130	130	130	
n-Φd	4-12	4-18	4-18	4-18	4-22	8-18	8-18	
ISO5211	F10	F14	F14	F14	F16	F25	F25	
Weight	Lbs	208.6	265.9	359	450.9	754.1	848.9	1051.8
	Kg	94.6	120.6	162.8	204.5	342	385	477

Note: Steam services are not recommended.

### Electric Butterfly Valves

PN16/235PSI/Class125

220V/ 380V • Multi-stage Aluminum Alloy Housing

Asynchronous Motor • Precision Gear

Moisture-proof Heating Resistor • Epoxy Resin Coating

90° Rotation • IP67 Protection

Dual-Flanged Style, Flange Dimension EN1092-2, ANSI B16.1 Class 125



HB970/S-EH/ RH

2" - 12"

Sealing Performance	
EPDM	-20°C- 120°C
NBR	-10°C- 80°C
VITON	-20°C- 150°C

Hydraulic Pressure Test	
Body	2.4Mpa/24Bar
Seat	1.76Mpa/17.6Bar

#### Materials List

No	Part	Specification	BS EN	ASTM
1	Body	Ductile Iron	BSEN 1563	A536 65-45-12
2	Bottom Stem	Stainless Steel	BSEN 10088-1	A582 420
3	Disc	Ductile Iron	BSEN 1563	A536 65-45-12
		Stainless Steel	BS970 304S15	CF8
		Aluminum Bronze	1400AB2	B148 Ay 954
4	Upper Stem	Stainless Steel	BSEN 10088-1	A582 420
5	Seat	EPDM	EPDM	EPDM
		NBR	NBR	NBR
		VITON	VITON	VITON
6	Bushing	Composite Material	PTFE&Bronze	PTFE&Bronze
7	Retaining Cap	Steel	BSEN 10087	A307
8	Electric Actuators	Other		

\* Figure number - EH for ON/OFF control, - RH for regulating control, 4~20mA or 0~10V, Please specify when ordering.

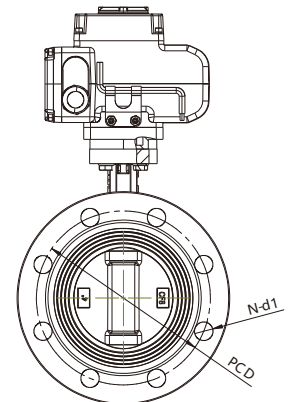
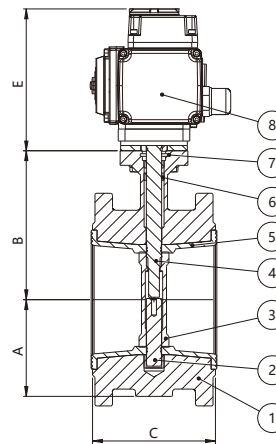
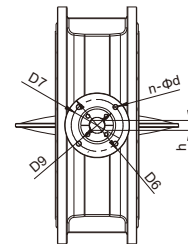

#### Dimensions

mm	50	65	80	100	125	150	200	250	300
In	2	2½	3	4	5	6	8	10	12
A	72	81	87	100	114	130	160	192	215
B	122	137	148	154	176	200	224	274	308
C	108	112	114	127	140	140	152	165	178
E	150	150	150	168	168	168	204	204	240
PCD	125	145	160	180	210	240	295	355	410
N-d1	4-19	4-19	8-19	8-19	8-19	8-23	12-23	12-28	12-28
h	9	9	9	11	14	14	17	22	24
D6	90	90	90	90	90	90	125	125	125
D7	70	70	70	70	70	70	102	102	102
D9	55	55	55	55	55	55	70	70	70
n-Φd	4-10	4-10	4-10	4-10	4-10	4-10	4-12	4-12	4-12
ISO5211	F07	F07	F07	F07	F07	F07	F10	F10	F10

Note: Steam services are not recommended.

### Electric Butterfly Valves

PN16/235PSI/Class125

220V/ 380V • Multi-stage Aluminum Alloy Housing

Asynchronous Motor • Precision Gear

Moisture-proof Heating Resistor • Epoxy Resin Coating

90° Rotation • IP67 Protection

Dual-Flanged Style, Flange Dimension EN1092-2, ANSI B16.1 Class 125



**HB970/S-EH/ RH**

14" - 28"

Sealing Performance	
EPDM	-20°C- 120°C
NBR	-10°C- 80°C
VITON	-20°C- 150°C

Hydraulic Pressure Test	
Body	2.4Mpa/24Bar
Seat	1.76Mpa/17.6Bar

#### Materials List

No	Part	Specification	BS EN	ASTM
1	Body	Ductile Iron	BSEN 1563	A536 65-45-12
2	Bottom Stem	Stainless Steel	BSEN 10088-1	A582 420
3	Disc	Ductile Iron	BSEN 1563	A536 65-45-12
		Stainless Steel	BS970 304S15	CF8
		Aluminum Bronze	1400AB2	B148 Ay 954
4	Upper Stem	Stainless Steel	BSEN 10088-1	A582 420
5	Seat	EPDM	EPDM	EPDM
		NBR	NBR	NBR
		VITON	VITON	VITON
6	Bushing	Composite Material	PTFE&Bronze	PTFE&Bronze
7	Retaining Cap	Steel	BSEN 10087	A307
8	Electric Actuators	Other		

\* Figure number - EH for ON/OFF control, - RH for regulating control, 4~20mA or 0~10V, Please specify when ordering.

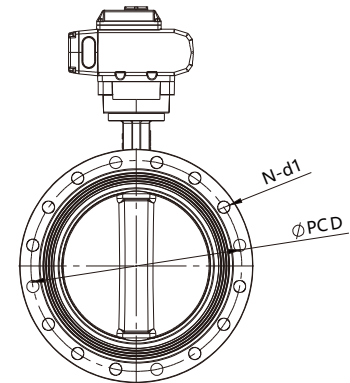
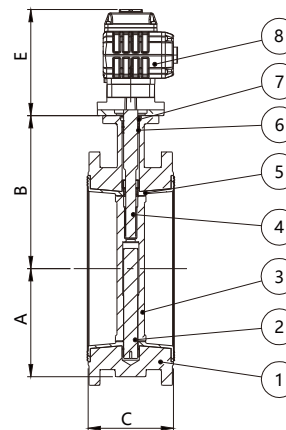
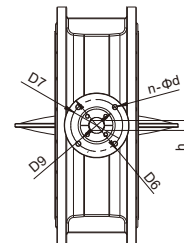

#### Dimensions

mm	350	400	450	500	600	700
In	14	16	18	20	24	28
A	270	305	330	350	420	517
B	330	365	400	445	505	616
C	190	216	222	229	267	292
E	158	158	158	158	-	-
PCD	470	525	585	650	770	840
N-d1	16-28	16-31	20-31	20-34	20-37	24-37
h	24	27	27	32	36	Key18*2
D6	125	175	175	175	210	300
D7	102	140	140	140	165	254
D9	70	100	100	100	130	130
n-Φd	4-12	4-18	4-18	4-18	4-22	8-18
ISO5211	F10	F14	F14	F14	F16	F25

Note: Steam services are not recommended.

### Ductile Iron Gate Valves PN16/235PSI/Class125

Non-Rising Stem, Solid Wedge, Bronze Seat  
Design to BS5150 and MSS SP-70  
Flange Dimension to EN1092-2, ANSI B16.1 Class 125

Hydraulic Pressure Test	
Body	2.4Mpa/24Bar
Seat	1.76Mpa/17.6Bar

Pressure Ratings	
	1.0 Mpa at 180°C
	1.6 Mpa at -10°C-120°C



**MG970-N**  
2" - 24"

#### Materials List

No	Part	Specification	BS EN	ASTM
1	Body	Ductile Iron	BSEN 1563	A536 65-45-12
2	Seat Sealing Ring	Cast Bronze	1982 CC491K	B62
3	Disc Sealing Ring	Cast Bronze	1982 CC491K	B62
4	Disc	Ductile Iron	BSEN 1563	A536 65-45-12
5	Stem Nut	Brass	12164 CW603N	B16
6	Stem	Brass	12164 CW603N	B16
7	Gasket	Graphite	--	--
8	Bolt	Steel	BSEN 10087	A307
9	Nut	Steel	BSEN 10087	A307
10	Bonnet	Ductile Iron	BSEN 1563	A536 65-45-12
11	Stud	Steel	BSEN 10087	A307
12	Nut	Steel	BSEN 10087	A307
13	Gland Box Gasket	Graphite	--	--
14	Gland Box	Ductile Iron	BSEN 1563	A536 65-45-12
15	Packing	Graphite	--	--
16	Seal Gland	Ductile Iron	BSEN 1563	A536 65-45-12
17	Handwheel	Cast Iron	BSEN 1561	A126 Class B
18	Gasket	Steel	BSEN 10087	A307
19	Nut	Steel	BSEN 10087	A307

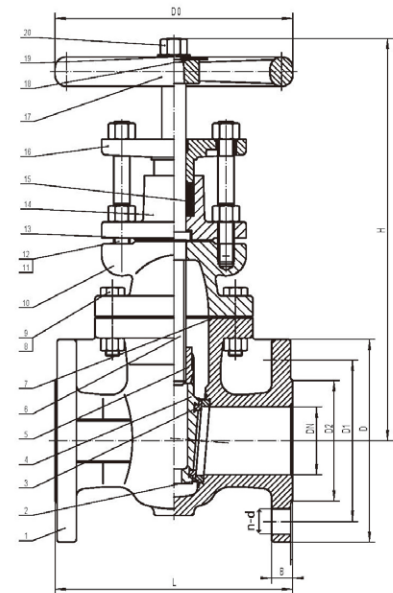

#### Dimensions-Weights

mm	50	65	80	100	125	150	200	250	300	350	400	450	500	600
In	2	2½	3	4	5	6	8	10	12	14	16	18	20	24
L	178	190	203	229	254	267	292	330	356	381	406	432	457	508
H	302	332	335	423	485	545	644	769	860	987	1044	1148	1257	1418
D	165	185	200	220	250	285	340	405	460	520	580	640	715	840
D1	125	145	160	180	210	240	295	355	410	470	525	585	650	770
D2	99	118	132	156	184	211	266	319	370	429	480	548	609	720
D0	178	178	200	254	300	300	348	400	457	560	560	610	610	765
B	20	20	22	24	26	26	30	32	32	36	38	40	42	48
n-d	4-19	4-19	8-19	8-19	8-19	8-23	12-23	12-28	12-28	16-28	16-31	20-31	20-34	20-37
Weight	Lbs	36	48	58	104	150	192	260	434	606	816	1039	1400	2646
	Kg	17	22	27	47	68	87	118	197	275	370	471	635	1200

### Ductile Iron Gate Valves PN16/235PSI/Class125

Outside Screw and Yoke, Solid Wedge, Bronze Seat  
Design to BS5150 and MSS SP-70  
Flange Dimension to EN1092-2, ANSI B16.1 Class 125



**MG970-R**  
2" - 24"

Hydraulic Pressure Test	
Body	2.4Mpa/24Bar
Seat	1.76Mpa/17.6Bar

Pressure Ratings	
	1.0 Mpa at 180°C
	1.6 Mpa at -10°C-120°C

#### Materials List

No	Part	Specification	BS EN	ASTM
1	Body	Ductile Iron	BSEN 1563	A536 65-45-12
2	Seat Sealing Ring	Cast Bronze	1982 CC491K	B62
3	Disc Sealing Ring	Cast Bronze	1982 CC491K	B62
4	Disc	Ductile Iron	BSEN 1563	A536 65-45-12
5	Stem	Brass	12164 CW603N	B16
6	Gasket	Graphite	--	--
7	Bolt	Steel	BSEN 10087	Steel A307
8	Nut	Steel	BSEN 10087	Steel A307
9	Bonnet	Ductile Iron	BSEN 1563	A536 65-45-12
10	Packing	Graphite	--	--
11	Seal Gland	Ductile Iron	BSEN 1563	A536 65-45-12
12	Bolt	Steel	BSEN 10087	Steel A307
13	Nut	Steel	BSEN 10087	Steel A307
14	Gland Bolt	Steel	BSEN 10087	Steel A307
15	Gland Nut	Steel	BSEN 10087	Steel A307
16	Yoke	Ductile Iron	BSEN 1563	A536 65-45-12
17	Yoke Bushing	Brass	12164 CW603N	B16
18	Screw	Steel	BSEN 10087	Steel A307
19	Yoke Nut	Cast Iron	BSEN 1563	A536 65-45-12
20	Handwheel	Cast Iron	BSEN 1563	A536 65-45-12
21	Handwheel Nut	Steel	BSEN 10087	Steel A307

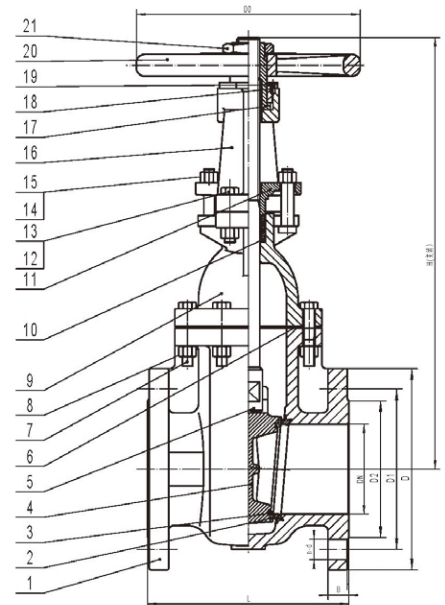

#### Dimensions-Weights

mm	50	65	80	100	125	150	200	250	300	350	400	450	500	600
In	2	2½	3	4	5	6	8	10	12	14	16	18	20	24
L	178	190	203	229	254	267	292	330	356	381	406	432	457	508
H	311	347	384	490	541	656	778	933	1102	1259	1395	1560	1708	1990
D	165	185	200	220	250	285	340	405	460	520	580	640	715	840
D1	125	145	160	180	210	240	295	355	410	470	525	585	650	770
D2	99	118	132	156	184	211	266	319	370	429	480	548	609	720
D0	178	178	200	254	300	300	348	400	457	560	560	610	610	765
B	20	20	22	24	26	26	30	32	32	36	38	40	42	48
n-d	4-19	4-19	8-19	8-19	8-19	8-23	12-23	12-28	12-28	16-28	16-31	20-31	20-34	20-37
Weight	Lbs	38	51	62	110	154	203	284	459	637	838	1014	1484	2701
	Kg	17	23	28	50	70	92	129	208	289	380	460	673	1225

### Ductile Iron Gate Valves

PN16/235PSI/Class125

Non-Rising Stem, Resilient Wedge, Epoxy Coating  
 Design to BS5150 and MSS SP-70  
 Flange Dimension EN1092-2, ANSI B16.1 Class 125



**FG970-EN**

1 1/2" – 12"

Hydraulic Pressure Test	
Body	2.4Mpa/24Bar
Seat	1.76Mpa/17.6Bar

Sealing Performance	
EPDM	-20°C- 120°C
NBR	-10°C- 80°C

#### Materials List

No	Part	Specification	BS EN	ASTM
1	Body	Ductile Iron	BSEN 1563	A536 65-45-12
2	Disc	Ductile Iron Coated With EPDM	BSEN 1563	A536 65-45-12
3	Stem Nut	Brass	12164 CW603N	B16
4	Bonnet	Ductile Iron	BSEN 1563	A536 65-45-12
5	Stem	Stainless Steel	BS970 420S37	A276 42000
6	Gland Nut	Brass	12164 CW603N	B16
7	Handwheel	Ductile Iron	BSEN 1563	A536 65-45-12

\* Fire protection water supply, drainage and water supply and non-corrosive gas

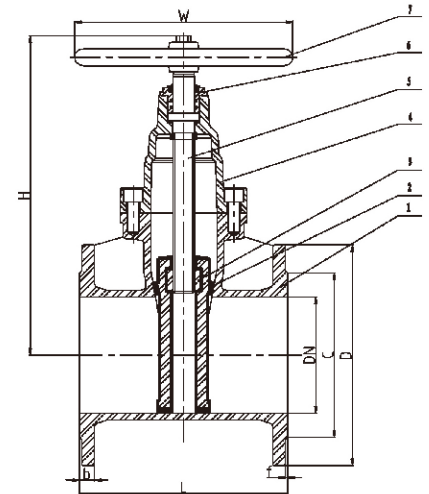
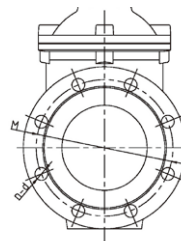

#### Dimensions-Weights

mm	40	50	65	80	100	125	150	200	250	300
In	1½	2	2½	3	4	5	6	8	10	12
L	165	178	190	203	229	254	267	292	330	356
H	240	250	265	300	350	410	450	550	650	710
C	88	102	122	138	158	188	212	268	320	378
D	150	165	185	200	220	250	285	340	405	460
M	110	125	145	160	180	210	240	295	355	410
b	19	19	19	19	19	19	19	20	22	24.5
n-d	4-19	4-19	4-19	8-19	8-19	8-19	8-23	12-23	12-28	12-28
Weight	Lbs	22	26	33	42	53	73	95	141	311
	Kg	10	12	15	19	24	33	43	64	141

### Ductile Iron Gate Valves PN16/235PSI/Class125

Non-Rising Stem, Resilient Wedge, Epoxy Coating  
Design to BS5150 and MSS SP-70  
Flange Dimension EN1092-2, ANSI B16.1 Class 125

Hydraulic Pressure Test	
Body	2.4Mpa/24Bar
Seat	1.76Mpa/17.6Bar

Sealing Performance	
EPDM	-20°C- 120°C
NBR	-10°C- 80°C

#### Materials List

No	Part	Specification	BS EN	ASTM
1	Body	Ductile Iron	BSEN 1563	A536 65-45-12
2	Disc	Ductile Iron Coated With EPDM	BSEN 1563	A536 65-45-12
3	Stem Nut	Brass	12164 CW603N	B16
4	Stem	Stainless Steel	BS970 420S37	A276 42000
5	Bonnet	Ductile Iron	BSEN 1563	A536 65-45-12
6	Gland	Ductile Iron	BSEN 1563	A536 65-45-12

\* Fire protection water supply, drainage and water supply and non-corrosive gas

#### Dimensions-Weights

mm	350	400	450	500	600	700	800
In	14	16	18	20	24	28	32
L	381	406	432	457	508	610	660
H	900	1030	1080	1188	1380	1545	1750
C	438	490	532	585	685	800	900
D	520	580	640	715	840	910	1025
M	470	525	585	650	770	840	950
b	32	32	34	34	36	38.5	43
f	4	4	4	4	5	5	5
W	600	600	600	750	750	960	1050
n-d	16-28	16-31	20-31	20-34	20-37	24-37	24-40
Weight	Lbs	421	558	717	948	1416	3308
	Kg	191	253	325	430	642	1500



**FG970-EN**

14" - 32"

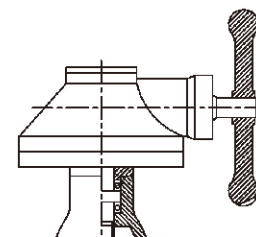
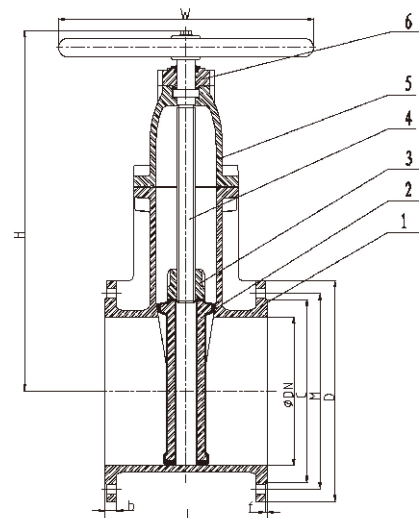

Operated by gearbox  
(for products with size  
above 28" )

### Ductile Iron Gate Valves PN25/350PSI

Non-Rising Stem, Resilient Wedge, Epoxy Coating  
Design to BS5150 and MSS SP-70  
Flange Dimension EN1092-2, ANSI B16.1 Class 250

Hydraulic Pressure Test	
Body	3.75Mpa/37.5Bar
Seat	2.75Mpa/27.5Bar

Sealing Performance	
EPDM	-20°C- 120°C
NBR	-10°C- 80°C



**FG975-EN**

1 1/2" - 16"

#### Materials List

No	Part	Specification	BS EN	ASTM
1	Body	Ductile Iron	BSEN 1563	A536 65-45-12
2	Disc	Ductile Iron Coated With EPDM	BSEN 1563	A536 65-45-12
3	Stem Nut	Brass	12164 CW603N	B16
4	Stem	Stainless Steel	BS970 420S37	A5276 42000
5	Bonnet	Ductile Iron	BSEN 1563	A536 65-45-12
6	Gasket	Rubber	NBR	NBR
7	O-Ring	Rubber	NBR	NBR
8	Gland	Brass	12164 CW603N	B16
9	Dust Cover	Rubber	NBR	NBR
10	Handwheel	Ductile Iron	BSEN 1563	A536 65-45-12

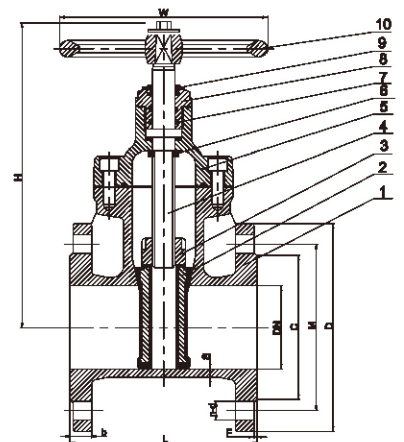

\* Fire protection water supply, drainage and water supply and non-corrosive gas

#### Dimensions-Weights

mm	40	50	65	80	100	125	150	200	250	300	350	400
In	1½	2	2½	3	4	5	6	8	10	12	14	16
L	165	178	190	203	229	254	267	292	330	356	381	406
H	260	270	283	311	352	435	485	520	632	745	835	953
C	88	102	122	138	162	188	218	278	335	395	450	505
D	150	165	185	200	235	270	300	360	425	485	555	620
M	110	125	145	160	190	220	250	310	370	430	490	550
S	8	8	8	9	10	11	12	14	16	18	19	20
b	19	19	19	19	19	19	20	22	24.5	27.5	30	32
f	3	3	3	3	3	3	3	3	3	4	4	4
W	160	180	180	200	250	280	300	350	400	500	600	600
n-d	4-19	4-19	8-19	8-19	8-23	8-28	8-28	12-28	12-31	16-31	16-34	16-37
Weight	Lbs	20	22	26	35	55	82	106	168	247	342	646
	Kg	9	10	12	16	25	37	48	76	112	155	293

### Ductile Iron Gate Valves PN16/235PSI/Class125

Outside Screw and Yoke, Resilient Wedge, Epoxy Coating  
Design to BS5150 and MSS SP-70  
Flange Dimension EN1092-2, ANSI B16.1 Class 125

Hydraulic Pressure Test	
Body	2.4Mpa/24Bar
Seat	1.76Mpa/17.6Bar

Sealing Performance	
EPDM	-20°C- 120°C
NBR	-10°C- 80°C



**FG970-ER**  
2" - 24"

#### Materials List

No	Part	Specification	BS EN	ASTM
1	Body	Ductile Iron	BSEN 1563	A536 65-45-12
2	Disc	Ductile Iron Coated With EPDM	BSEN 1563	A536 65-45-12
3	Stem Nut	Brass	12164 CW603N	B16
4	Stem	Stainless Steel	BS970 420S37	A276 42000
5	Bonnet	Ductile Iron	BSEN 1563	A536 65-45-12
6	Packing	Graphite	Gr	Gr
7	Gland	Ductile Iron	BSEN 1563	A536 65-45-12
8	Support	Ductile Iron	BSEN 1563	A536 65-45-12
9	Stem Nut	Brass	12164 CW603N	B16
10	Handwheel	Ductile Iron	BSEN 1563	A536 65-45-12

\* Fire protection water supply, drainage and water supply and non-corrosive gas

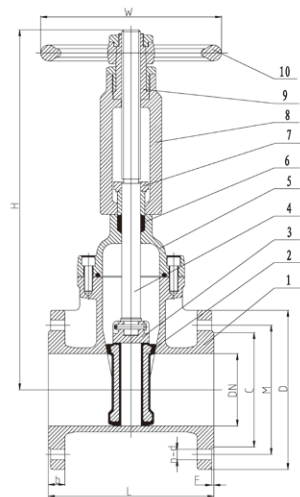

#### Dimensions-Weights

mm	50	65	80	100	125	150	200	250	300	350	400	450	500	600	
In	2	2½	3	4	5	6	8	10	12	14	16	18	20	24	
L	178	190	203	229	254	267	292	330	356	381	406	432	457	508	
H	350	370	380	405	455	490	540	720	860	1185	1355	1570	1830	2150	
C	99	118	132	156	184	211	266	319	370	429	480	530	582	682	
D	165	185	200	220	250	285	340	405	460	520	580	640	715	840	
M	125	145	160	180	210	240	295	355	410	470	525	585	650	770	
b	19	19	19	19	19	19	20	22	24.5	26.5	28	30	32	36	
F	3	3	3	3	3	3	3	3	3	4	4	4	4	5	
W	200	200	250	280	280	350	400	450	540	600	600	600	750	750	
n-d	4-19	4-19	8-19	8-19	8-19	8-23	12-23	12-28	12-28	16-28	16-31	20-31	20-34	20-37	
Weight	Lbs	40	46	62	79	126	168	243	340	474	725	897	1191	1544	1985
	Kg	18	21	28	36	57	76	110	154	215	329	407	540	700	900

### Ductile Iron Gate Valves PN25/350PSI

Outside Screw and Yoke, Resilient Wedge, Epoxy Coating  
Design to BS5150 and MSS SP-70  
Flange Dimension EN1092-2, ANSI B16.1 Class 250

Hydraulic Pressure Test	
Body	3.75Mpa/37.5Bar
Seat	2.75Mpa/27.5Bar

Sealing Performance	
EPDM	-20°C- 120°C
NBR	-10°C- 80°C



**FG975-ER**  
2" - 16"

#### Materials List

No	Part	Specification	BS EN	ASTM
1	Body	Ductile Iron	BSEN 1563	A536 65-45-12
2	Disc	Ductile Iron Coated With EPDM	BSEN 1563	A536 65-45-12
3	Stem Nut	Brass	12164 CW603N	B16
4	Stem	Stainless Steel	BS970 420S37	A276 42000
5	Bonnet	Ductile Iron	BSEN 1563	A536 65-45-12
6	Packing	Graphite	Gr	Gr
7	Gland	Ductile Iron	BSEN 1563	A536 65-45-12
8	Support	Ductile Iron	BSEN 1563	A536 65-45-12
9	Stem Nut	Brass	12164 CW603N	B16
10	Handwheel	Ductile Iron	BSEN 1563	A536 65-45-12

\* Fire protection water supply, drainage and water supply and non-corrosive gas

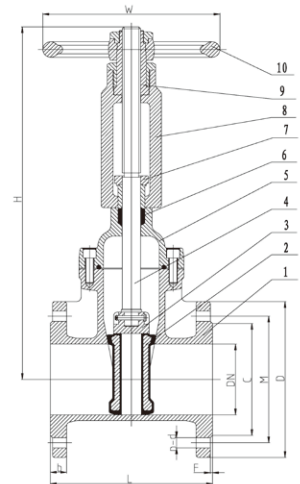

#### Dimensions-Weights

mm	50	65	80	100	125	150	200	250	300	350	400
In	2	2½	3	4	5	6	8	10	12	14	16
L	178	190	203	229	254	267	292	330	356	381	406
H	350	370	380	405	455	490	540	720	860	1185	1355
C	102	122	138	162	188	218	278	335	395	450	505
D	165	185	200	235	270	300	360	425	485	555	620
M	125	145	160	190	220	250	310	370	410	470	550
b	21	21	21	21	21	21	22	24	26.5	28.5	30
F	3	3	3	3	3	3	3	3	3	4	4
W	200	200	250	280	280	350	400	450	540	600	600
n-d	4-19	4-19	8-19	8-19	8-19	8-23	12-23	12-28	12-28	16-28	16-31
Weight	Lbs	40	46	62	84	137	183	265	366	514	986
	Kg	18	21	28	38	62	83	120	166	233	447

### Ductile Iron Globe Valves

PN16/235PSI/Class125

Outside Screw and Yoke, Bronze Seat

Design to BS5152 and MSS SP-85

Flange Dimension to EN1092-2, ANSI B16.1 Class 125



**GL970-R**

2" - 12"

Hydraulic Pressure Test	
Body	2.4Mpa/24Bar
Seat	1.76Mpa/17.6Bar

Pressure Ratings	
	1.0 Mpa at 180°C
	1.6 Mpa at -10°C-120°C

#### Materials List

No	Part	Specification	BS EN	ASTM
1	Body	Ductile Iron	BSEN 1563	A536 65-45-12
2	Seat Sealing Ring	Cast Bronze	1982 CC491K	B62
3	Disc Sealing Ring	Cast Bronze	1982 CC491K	B62
4	Disc	Ductile Iron	BSEN 1563	A536 65-45-12
5	Thrust Washer	Stainless Steel	BSEN 10088-1	AISI 304
6	Nut	Cast Brass	12164 CW603N	B16
7	Stem	Brass	12164 CW603N	B16
8	Flange Gasket	Graphite	--	--
9	Bolt	Steel	BSEN 10087	Steel A307
10	Packing	Graphite	--	--
11	Bonnet	Ductile Iron	BSEN 1563	A536 65-45-12
12	Seal Gland	Ductile Iron	BSEN 1563	A536 65-45-12
13	Nut	Steel	BSEN 10087	Steel A307
14	Bolt	Steel	BSEN 10087	Steel A307
15	Stem Nut	Cast Brass	12164 CW603N	B16
16	Handwheel	Cast Iron	BSEN 1561	A126 Class B
17	Gasket	Steel	BSEN 10087	Steel A307
18	Nut	Steel	BSEN 10087	Steel A307

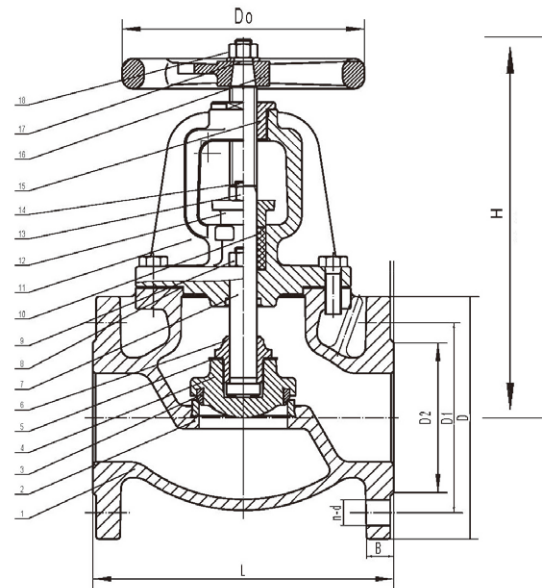

#### Dimensions-Weights

mm	50	65	80	100	125	150	200	250	300	
In	2	2½	3	4	5	6	8	10	12	
L	203	216	241	292	330	356	495	622	699	
H	315	345	387	490	576	680	808	1010	1080	
D	165	185	200	220	250	285	340	405	460	
D1	125	145	160	180	210	240	295	355	410	
D2	99	118	132	156	184	211	266	319	370	
D0	178	178	200	254	300	300	348	400	457	
B	20	20	22	24	26	26	30	32	32	
n-d	4-19	4-19	8-19	8-19	8-19	8-23	12-23	12-28	12-28	
Weight	Lbs	34	47	68	99	151	204	346	483	673
	Kg	16	22	31	45	68	93	157	219	305

### Ductile Iron Check Valves

PN16/235PSI/Class125

Horizontal Swing, Bronze Seat

Design to BS5153 and MSS SP-71

Flange Dimension to EN1092-2, ANSI B16.1 Class 125



**CF970-Y**

2" - 24"

Hydraulic Pressure Test	
Body	2.4Mpa/24Bar
Seat	1.76Mpa/17.6Bar

Pressure Ratings	
	1.0 Mpa at 180°C
	1.6 Mpa at -10°C-120°C

#### Materials List

No	Part	Specification	BS EN	ASTM
1	Body	Ductile Iron	BSEN 1563	A536 65-45-12
2	Seat Sealing Ring	Cast Bronze	1982 CC491K	B62
3	Disc Sealing Ring	Cast Bronze	1982 CC491K	B62
4	Disc	Ductile Iron	BSEN 1563	A536 65-45-12
5	Support	Ductile Iron	BSEN 1563	A536 65-45-12
6	Gasket	Steel	BSEN 10087	Steel A307
7	Nut	Steel	BSEN 10087	Steel A307
8	Safety Pin	Stainless Steel	BSEN 10088-1	AISI 304
9	Screw	Steel	BSEN 10087	Steel A307
10	Support Pin	Brass	12164 CW603N	B16
11	Gasket	Steel	BSEN 10087	Steel A307
12	Safety Pin	Stainless Steel	BSEN 10088-1	AISI 304
13	Bonnet	Ductile Iron	BSEN 1563	A536 65-45-12
14	Bonnet Gasket	Graphite	--	--
15	Bolt	Steel	BSEN 10087	Steel A307
16	Nut	Steel	BSEN 10087	Steel A307

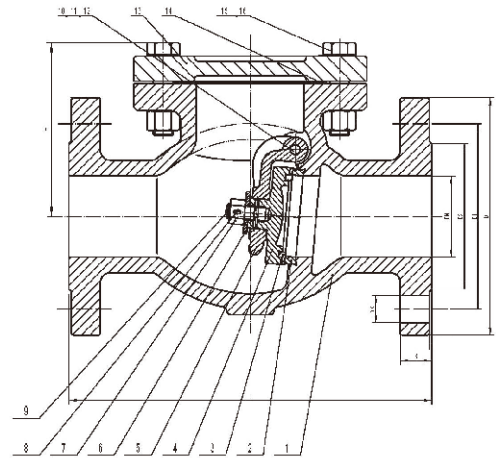

#### Dimensions-Weights

mm	50	65	80	100	125	150	200	250	300	350	400	450	500	600	
In	2	2½	3	4	5	6	8	10	12	14	16	18	20	24	
L	203	216	241	292	330	356	495	622	699	787	914	914	1016	1219	
H	112	132	141	162	192	211	270	316	357	560	589	645	702	812	
D	165	185	200	220	250	285	340	405	460	520	580	640	715	840	
D1	125	145	160	180	210	240	295	355	410	470	525	585	650	770	
D2	99	118	132	156	184	211	266	319	370	429	480	548	609	720	
B	20	20	22	24	26	26	30	32	32	36	38	40	42	48	
n-d	4-19	4-19	8-19	8-19	8-19	8-23	12-23	12-28	12-28	16-28	16-31	20-31	20-34	20-37	
Weight	Lbs	26	39	47	82	124	160	271	443	642	935	1195	1446	1835	2778
	Kg	12	18	21	37	56	72	123	201	291	424	542	656	832	1260

### Ductile Iron Silent Check Valves PN16/235PSI/Class 125

Globe Style Center-Oriented, Spring Actuated  
Flange Dimension EN1092-2, ANSI B16.1 Class 125



**CF970-V**  
2" - 16"

Hydraulic Pressure Test	
Body	2.4Mpa/24Bar
Seat	1.76Mpa/17.6Bar

Sealing Performance	
EPDM	-20°C- 120°C
NBR	-10°C- 80°C

#### Materials List

No	Part	Specification	BS EN	ASTM
1	Body	Ductile Iron	BSEN1563	A536 65-45-12
2	Seat Body	Ductile Iron	BSEN1563	A536 65-45-12
3	Seat	Rubber	EPDM	EPDM
4	Disc	Ductile Iron/Stainless Steel	BSEN1563	A536 65-45-12
5	Stem	Stainless Steel	BS970 304S15	S30400
6	Bushing	Brass	BS2874	B16 C36000
7	Spring	Stainless Steel	BS970 304S15	S30400
8	Screw	Stainless Steel	BS970 304S15	S30400
9	Ball	Stainless Steel	BS970 304S15	S30400

\* Applicable to water supply system pipelines

\* Stainless steel shell, valve core & stem assembly (Fig. CF370V)

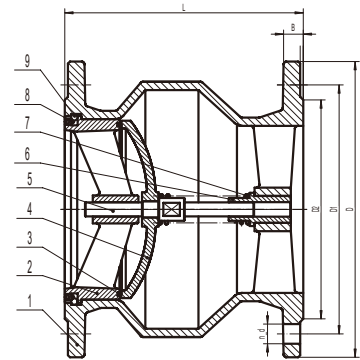

#### Dimensions-Weights

mm	50	65	80	100	125	150	200	250	300	350	400	
In	2	2½	3	4	5	6	8	10	12	14	16	
L	133	140	152	185	216	230	259	362	393	400	448	
D	165	185	200	220	250	285	340	405	460	520	580	
D1	125	145	160	180	210	240	295	355	400	470	525	
D2	99	118	132	156	184	211	266	319	370	429	480	
B	19	19	19	19	19	19	20	22	24.5	26.5	28	
n-d	4-19	4-19	8-19	8-19	8-19	8-23	12-23	12-28	12-28	16-28	16-31	
Weight	Lbs	17	21	22	30	41	55	87	155	210	316	--
	Kg	8	9	10	14	19	25	40	70	95	143	--

**Notes:**

\* Silent check valves should be installed at the outlets of pumps.

\* Valves may be installed in any positions of horizontal or vertical pipelines, Not applicable to air compression pipelines.

### Ductile Iron Silent Check Valves PN25/350PSI/Class 250

Globe Style Center-Oriented, Spring Actuated  
Flange Dimension EN1092-2, ANSI B16.1

Hydraulic Pressure Test	
Body	3.75Mpa/37.5Bar
Seat	2.75Mpa/27.5Bar

Sealing Performance	
EPDM	-20°C- 120°C
NBR	-10°C- 80°C



**CF975-V**  
2" - 16"

#### Materials List

No	Part	Specification	BS EN	ASTM
1	Body	Ductile Iron	BSEN1563	A536 65-45-12
2	Seat Body	Ductile Iron	BSEN1563	A536 65-45-12
3	Seat	Rubber	EPDM	EPDM
4	Disc	Ductile Iron/Stainless Steel	BSEN1563	A536 65-45-12
5	Stem	Stainless Steel	BS970 304S15	S30400
6	Bushing	Brass	BS2874	B16 C36000
7	Spring	Stainless Steel	BS970 304S15	S30400
8	Screw	Stainless Steel	BS970 304S15	S30400
9	Ball	Stainless Steel	BS970 304S15	S30400

\* Applicable to water supply system pipelines

\* Stainless steel shell, valve core & stem assembly (Fig. CF370V)

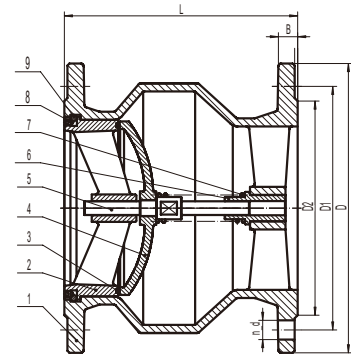

#### Dimensions-Weights

mm	50	65	80	100	125	150	200	250	300	350	400
In	2	2½	3	4	5	6	8	10	12	14	16
L	133	140	152	185	216	230	259	362	393	400	448
D	165	185	200	235	270	300	360	425	485	555	620
D1	125	145	160	190	220	250	310	370	430	490	550
D2	99	118	132	156	184	211	274	330	389	448	503
B	19	19	19	19	19	20	22	24.5	27.5	30	32
n-d	4-19	8-19	8-19	8-23	8-28	8-28	12-28	12-31	16-31	16-34	16-37
Weight	Lbs	17	21	22	34	44	62	102	178	246	--
	Kg	8	9	10	15	20	28	46	81	112	--

**Notes:**

\* Silent check valves should be installed at the outlets of pumps.

\* Valves may be installed in any positions of horizontal or vertical pipelines, Not applicable to air compression pipelines.

# Dual Plate Check Valves

## PN16/235PSI/Class125

Wafer Style, Rubber Seat, Spring Actuated

Design to EN12334:2001/API594

Flange Dimension EN1092-2, ANSI B16.1 Class 125



**CF900-X**

1½" – 32"

Hydraulic Pressure Test	
Body	2.4Mpa/24Bar

Pressure Rating	
	1.6 Mpa at -10°C-120°C

### Materials List

No	Part	Specification	BS EN	ASTM
1	Body	Ductile Iron	BSEN1563	A536 65-45-12
2	Disc	Stainless Steel	BS970 304S15	A351 CF8
3	Spring	Stainless Steel	BS EN10088-1	AISI 304
4-5	Stem	Stainless Steel	BS EN10088-1	AISI 304
6	Plug	Carbon Steel	BS EN10088-1	BS AISI 304
7	Washer	VITON	PTFE	PTFE
8	Spring Washer	VITON	PTFE	PTFE
9	Lifting Bolt	Carbon Steel	BSEN 10087	Steel A307
10	Seat	Rubber	EPDM	EPDM

\* Applicable to water supply system pipelines

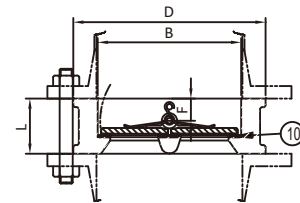
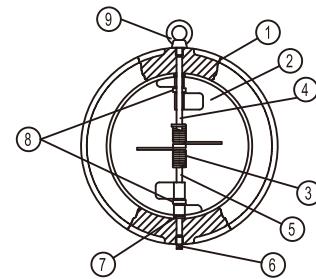

### Dimensions-Weights

mm	40	50	65	80	100	125	150	200	250	300	350	400	450	500	600	700	800	
In	1½	2	2½	3	4	5	6	8	10	12	14	16	18	20	24	28	32	
L	43	43	46	64	64	70	76	89	114	114	127	140	152	152	178	229	241	
D	ANSI	82	102	121	134	171	193	219	276	336	406	448	511	546	603	717	825	
	EN	92	107	127	142	162	192	218	273	328	378	438	489	539	616	733	804	
B	57	65	80	94	117	145	170	224	265	310	360	410	450	505	624	720	825	
F	19	19	20	28	27	30	31	33	50	43	45	52	58	58	73	98	100	
Weight	Lbs	2.32	4	5	8	11	15	20	34	59	81	121	161	223	258	390	483	725
	Kg	1.05	2	2	4	5	7	9	16	27	37	55	73	101	117	177	219	329

\* Valves may be installed in any position, horizontal or vertical pipelines, They are not applicable to air compression pipelines.

### Ball Non-Return Valves

PN16/235PSI/Class125

Spherical Rubber Disc

BSEN1074-3 and BSEN12334

Flange Dimension EN1092-2, ANSI B16.1 Class 125



**CF970-B**

2" - 24"

Hydraulic Pressure Test	
Body	2.4Mpa/24Bar

Pressure Rating	
EPDM	-20°C-120°C
NBR	-10°C-80°C

#### Materials List

No	Part	Specification	BS EN	ASTM
1	Body	Ductile Iron	BSEN 1563	A536 65-45-12
2	Ball	Steel/Rubber	Steel+EPDM/NBR	
3	Sealing Ring	Rubber	NBR	NBR
4	Bonnet	Ductile Iron	BSEN 1563	A536 65-45-12
5	Bolt	Stainless Steel	BS970 304S	AISI 304

\* Applicable to water supply and drainage pipelines

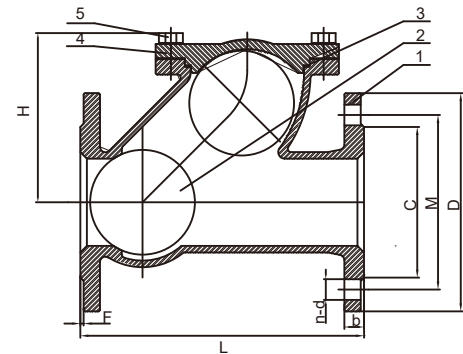

#### Dimensions

mm	50	65	80	100	125	150	200	250	300	350	400	500	600
In	2	2½	3	4	5	6	8	10	12	14	16	20	24
L	203	216	241	292	330	356	495	622	698	787	914	978	1295
H	108	132	151	198	210	270	368	471	531	613	690	882	1050
D	165	185	200	220	250	285	340	405	460	520	580	715	840
M	125	145	160	180	210	240	295	355	410	470	525	650	770
C	99	118	132	156	184	211	266	319	370	429	480	609	720
b	19	19	19	19	19	19	20	22	24.5	26.5	28	31.5	36
F	3	3	3	3	3	3	3	3	4	4	4	4	4
n-d	4-19	4-19	8-19	8-19	8-19	8-19	12-23	12-28	12-28	16-28	16-31	20-34	20-37

### Ductile Iron Y Strainer

PN16/235PSI/Class125

Stainless Steel Screen, Drain Outlet

Flange Dimension EN1092-2, ANSI B16.1 Class 125

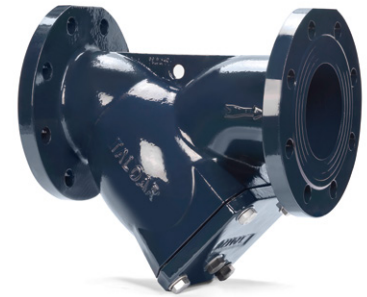

**YR-970**

2" – 16"

Hydraulic Pressure Test	
Body	2.4Mpa/24Bar

Pressure Ratings	
1.0 Mpa at 180°C	
1.6 Mpa at -10°C-120°C	

#### Materials List

No	Part	Specification	BS EN	ASTM
1	Body	Ductile Iron	EN JS1030	A536 65-45-12
2	Screen	Stainless Steel	BSEN 10088-1	AISI 304
3	Sealing Ring	EPDM	--	--
4	Bonnet	Ductile Iron	EN JS1030	A536 65-45-12
5	Drain Plug	Stainless Steel	BSEN 10088-1	AISI 304
6	Bolt	Stainless Steel	BSEN 10088-1	AISI 304

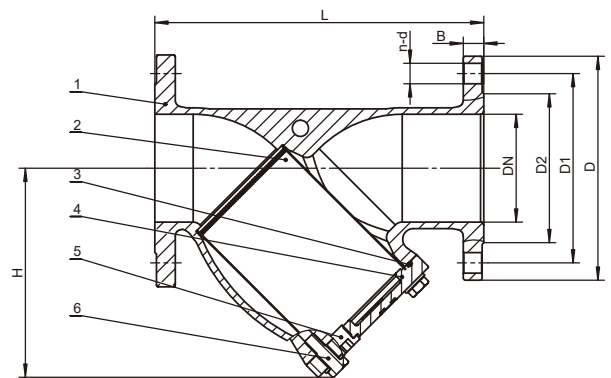

#### Dimensions-Weights

mm	50	65	80	100	125	150	200	250	300	350	400
<b>In</b>	2	2½	3	4	5	6	8	10	12	14	16
<b>L</b>	216	241	283	305	381	403	495	622	698	787	914
<b>H</b>	128	145	160	210	228	260	324	416	460	540	598
<b>D</b>	165	185	200	220	250	285	340	405	455	520	580
<b>D1</b>	125	145	160	180	210	240	295	355	410	470	525
<b>D2</b>	99	118	132	156	184	211	266	319	370	429	480
<b>B</b>	19	19	19	19	19	19	20	22	24.5	26.5	28
<b>n-d</b>	4-19	4-19	8-19	8-19	8-19	8-23	12-23	12-28	12-28	16-28	16-31
<b>Weight</b>	<b>Lbs</b>	18	22	27	38	50	57	107	173	263	379
	<b>Kg</b>	8	10	12	17	23	26	49	79	119	172

### Ductile Iron Y Strainer

PN25/350PSI/Class250

Stainless Steel Screen, Drain Outlet

Flange Dimension EN1092-2, ANSI B16.1 Class 125



**YR-975**

2" - 16"

Hydraulic Pressure Test	
Body	3.75Mpa/37.5Bar

Pressure Ratings	
	1.0 Mpa at 180°C
	1.6 Mpa at -10°C-120°C

#### Materials List

No	Part	Specification	BS EN	ASTM
1	Body	Cast Iron	BSEN 1563	A536 65-45-12
2	Screen	Stainless Steel	BSEN 10088-1	AISI 304
3	Bonnet	Cast Iron	BSEN 1563	A536 65-45-12
4	Gasket	Graphite	--	--
5	Drain Plug	Stainless Steel	BSEN 10088-1	AISI 304
6	Bolt	Stainless Steel	BSEN 10088-1	AISI 304

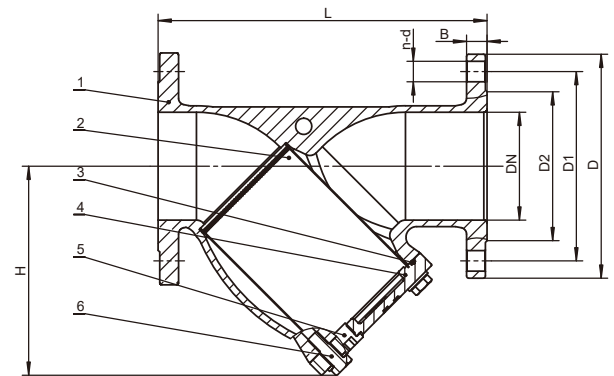

#### Dimensions-Weights

mm	50	65	80	100	125	150	200	250	300	350	400	450	500	600	
In	2	2½	3	4	5	6	8	10	12	14	16	18	20	24	
L	216	241	283	305	381	403	495	622	698	787	914	1200	1250	1450	
H	128	145	160	210	228	260	324	416	460	540	598	795	862	985	
D	165	185	200	235	270	300	360	425	485	555	620	670	730	845	
D1	125	145	160	190	220	250	310	370	430	490	550	600	660	770	
D2	99	118	132	165	184	211	274	330	389	448	503	548	609	720	
B	19	19	19	19	19	20	22	24.5	27.5	30	32	34.5	36.5	42	
n-d	4-19	8-19	8-19	8-23	8-28	8-28	12-28	12-31	16-31	16-34	16-37	20-37	20-37	20-41	
Weight	Lbs	21	271	34	57	71	101	154	269	379	739	1056	1151	--	--
	Kg	9	12	15	26	32	46	70	122	172	335	479	522	--	--

### Ductile Iron Foot Valves

PN16/235PSI/Class 125

Large Flow, Stainless Steel Screen

Flange Dimension EN1092-2, ANSI B16.1 Class 125



**TF-970**

2" - 20"

Hydraulic Pressure Test	
Body	2.4Mpa/24Bar

Sealing Performance	
NBR	-10°C- 80°C
VITON	-20°C- 150°C

#### Materials List

No	Part	Specification	BS EN	ASTM
1	Body	Ductile Iron	BSEN 1563	A536 65-45-12
2	Upper Seat	Ductile Iron	BSEN 1563	A536 65-45-12
3	Stem	Stainless steel	BS970 304S15	AISI 304
4	Disc	Ductile Iron	BSEN 1563	A536 65-45-12
5	Lower Seat	Ductile Iron	BSEN 1563	A536 65-45-12
6	Washer	Rubber	NBR/VITON	NBR/VITON
7	Pull Rod	Ductile Iron	BSEN 1563	A536 65-45-12
8	Strainer Screen	Stainless Steel	BS970 304S15	AISI 304
9	Chassis	Ductile Iron	BSEN 1563	A536 65-45-12

\* Used at the bottom of reservoirs.

\* Stainless steel shell, valve core & stem assembly (Fig.TF370)

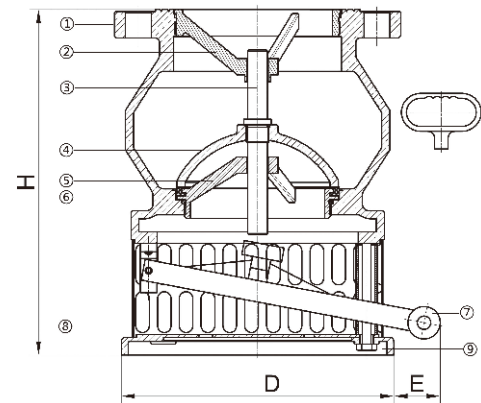

#### Dimensions-Weights

mm	50	65	80	100	125	150	200	250	300	350	400	450	500
In	2	2½	3	4	5	6	8	10	12	14	16	18	20
H	200	200	240	260	270	290	393	420	470	600	709	720	950
D	140	150	175	200	235	275	330	425	445	550	650	700	760
E	16	40	30	40	50	25	40	60	--	--	--	--	--
Weight	Lbs	11	19	20	24	37	48	108	132	214	401	573	684
	Kg	5	8.5	9	11	17	22	49	60	97	182	260	310

### Stainless Steel Vent Valves PN16/235PSI

Large Venting Volume, Stainless Steel Float  
Threaded Ends Comply to BS21 or ANSI 2.1

Maximum Pressure Range	
1/2" - 1"	7-12Bar

Maximum Temperature Range	
120°C/220°C	



**VT-360**  
1/2" - 1"

#### Materials List

No	Part	Specification	BS EN	ASTM
1	Bonnet	Stainless Steel	BS970 316S16	A351 CF8M
2	Gasket	Stainless Steel	BS970 304S15	AISI 304
3	Vent Plug	Rubber	EPDM/ VITON	EPDM/ VITON
4	Float	Stainless Steel	BS970 304S15	AISI 304
5	Body	Stainless Steel	BS970 316S16	A351 CF8M

\* Applicable to cold/hot water supply system pipelines.

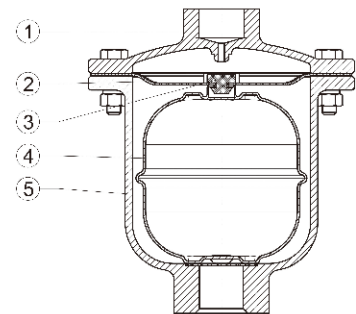
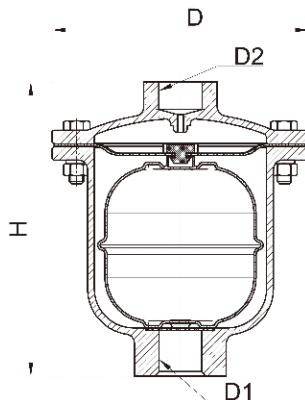

#### Dimensions-Weights

mm		15	20	25
In		1/2	3/4	1
H		126	126	126
D		112	112	112
D1		1/2" PT/NPT	3/4" PT/NPT	1" PT/NPT
D2		3/8" or 1/2" BSPT/NPT		
Weight	Lbs	3.09	3.09	3.09
	Kg	1.4	1.4	1.4

#### Installation tip!

Vent valves should be vertically installed on the top of piping devices.

### Butterfly Valve Torque Table (235PSI / 285PSI)

#### HB950/HB350 Series Wafer Type Butterfly Valves PN16/ 235PSI

mm	40	50	65	80	100	125	150	200	250	300	350	400	450	500	600
In	½	2	2½	3	4	5	6	8	10	12	14	16	18	20	24
In. Lbs	97	115	151	204	354	549	930	1701	2880	4341	5538	7487	10012	12670	20378
N. m	11	13	17	23	40	62	105	192	325	490	625	845	1130	1430	2300

#### HB970 Series Flanged Butterfly Valves PN16 / 235PSI

mm	50	65	80	100	125	150	200	250	300	350	400	450	500	600
In	2	2½	3	4	5	6	8	10	12	14	16	18	20	24
In. Lbs	97	159	328	399	620	975	1949	3367	4430	8506	13290	15948	17720	25251
N. m	11	18	37	45	70	110	220	380	500	960	1500	1800	2000	2850

#### HB970 Series Flanged Butterfly Valves PN16 / 235PSI

mm	700	800	900	1000	1200
In	28	32	36	40	48
In. Lbs	52983	69640	117041	164796	217070
N. m	5980	7860	13210	18600	24500

#### HB973 Series Flanged Butterfly Valves PN20 / 285PSI

mm	50	65	80	100	125	150	200	250	300	350	400	450	500	600
In	2	2½	3	4	5	6	8	10	12	14	16	18	20	24
In. Lbs	115	186	354	425	638	1063	2126	3163	5024	9657	15018	18181	20307	29327
N. m	13	21	40	48	72	120	240	357	567	1090	1695	2052	2292	3310

#### Notes:

1. The torque values are applicable to opening/closing operation of butterfly valves for water or other non-lubricating media.
2. In case the medium is dry compressed air, the torque will be larger. New torque values should be calculated by the factory.
3. When the medium temperature is extremely low, the rubber valve seat will be harden and the valve operating torque will obviously increase.
4. The valve seats mentioned above are sealed with EPDM or NBR rubber. If VITON, silicone rubber and other hard sealing materials are used, valve opening/closing resistance will increase. Hence, new torque values should be calculated by the factory.
5. Torque values in the table are actual operating torque values for butterfly valves. It is recommended to increase by at least 30% as a safety factor when electric or pneumatic controllers are used.
6. TALOAR butterfly valves with resilient seats are opened/closed to control the flow by lever. For 2" - 6" butterfly valves, lever operator under 150PSI, 235PSI or 285PSI. For butterfly valves in size of 8" or above, the operating torque and counter-acting force generated inside valves may exceed their respective limits. In this case gear operator is suggested for safety.

## Parameters for Butterfly Valve Lever and Gear Operators

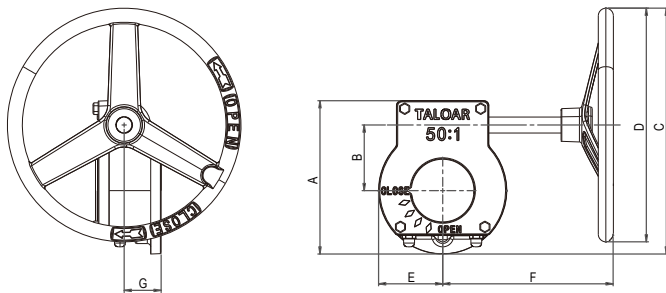
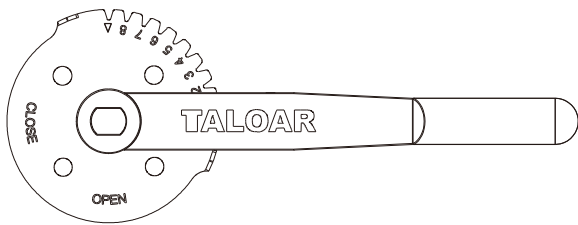
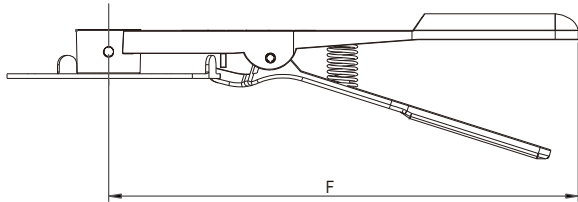

### Dimensions-Weights

mm	50-150	
In	2-6	
F	254	
Weight	Lbs.	1.1
	Kg.	0.5

### Materials List

Part	Specification
Lever & Worm Gear	Cast Iron(Epoxy Spray Coating)
Dial	Nickel-Plated Carbon Steel

### Materials List

Part	Specification
Body& Cover& Worm Gear	Cast Iron
Worm Shaft	Stainless Steel ANSI420
Fasteners	Stainless Steel ANSI304
Position Indicator	Nickel-Plated Carbon Steel

### Dimensions-Weights

mm	50 - 150	200 - 250	300 - 350	400	450	500	600
In	2 - 6	8 - 10	12 - 14	16	18	20	24
Part Number	24:1	30:1	50:1	70:1	70:1	70:1	208:1
N.m	150	500	1200	2000	2000	2000	4000
A	116	143	183	256	256	256	286
B	44	52.5	77.5	112	112	112	41.5
C	158	260	295	445	445	445	385
D	137	280	280	390	390	390	385
E	46	62	76	105	105	105	130
F	153	208	203	271	271	271	330
G	34	48.5	44	62	62	62	152
Weight	Lbs.	6.2	14.3	16.8	49.8	49.8	105.8
	Kg.	2.8	6.5	7.6	22.6	22.6	48

### TALOAR Electric Control Solution

#### Product Performance:

- 90° rotary switch for throttle control in the butterfly valves or the ball valves.
- ON/OFF type and regulating type control for selection, with an external handwheel operator.
- Torque: 13 Nm-5,000 Nm.
- 360° angle of view, to clearly observe the stroke of the electric actuator.
- Safe and automatic switching between manual and automatic modes, regardless of power-on or power-off state, without the help of the clutch.
- An independent IP68 terminal box, no need to open the upper cover of the actuator.
- ISO5211 mounting interface, with square hole, keyway or other spline sleeve provided for easy exchange.
- Meeting AC 110~120 V/AC 220 V~240 V/AC 380~440 V & AC/DC 24 V power supply standards.
- Hard aluminum alloy shell with oxidation-treated and polyester powder coating: light and compact.
- Shell with enclosed-seal, highly applicable and reliable to be used for outdoors or underwater applications.
- In case of over torque, the temperature control switch for the motor will cut off the power supply automatically to protect the motor.
- A combination of an internal gear and a planetary gear, worm gear lever for manual transmission, with self-locking function.

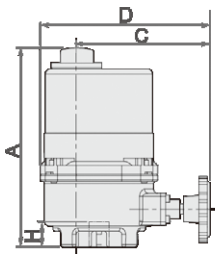

ET-050H ~ ET-120

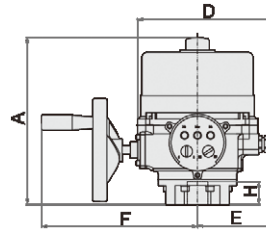
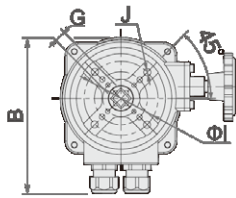

ET-130 ~ ET-1300

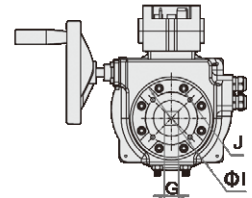
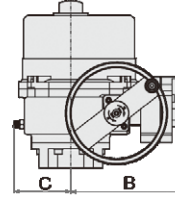

#### Technical Parameters of Electric Actuators:

Figure/Dimension	A	B	C	D	G	H	ΦI	J
ET/RM050H~090H	188/218	145	108	165	11*11	20	36/50/70	4-M5 ~ M8
ET/RM-120		145	108	165	14*14	20		

Figure/Dimension	A	B	C	D	E	F	G	H	ΦI	J
ET/RM-130	265	123	79	216	120	240	14*18.92	35	70	4-M8
ET/RM-160	265	123	79	216	120	240	14*18.92	35	70/102	4-M8/M10
ET/RM-235	321	187	103	262	150	297	17*22.1	55	102	4-M10
ET/RM-300	321	187	103	262	150	297	22*28.45	55	102/125	4-M10/M12
ET/RM-400	321	187	103	262	150	297	24*31.6	55	125	4-M12
ET/RM-635	321	187	103	262	150	297	24*31.6	55	125/140	4-M12/M16
ET/RM-800	378	241	119	293	161	346	27*37.95	65	125/140	4-M12/M16
ET/RM-835	378	241	119	293	161	346	27*42.86	65	125/140	4-M12/M16
ET/RM-900	378	241	119	293	161	346	32*45.72	65	125/140/165	4-M12/M16/M20
ET/RM-1200	532	116	215	293	302	182	36*53.98	85	140/165	4-M16/M20
ET/RM-1300	532	116	215	293	302	182	36*53.98	85	140/165	4-M16/M20

\* The actuators have both manual and electric control functions and are equipped with handwheel operators. ET for ON/OFF control; RM for regulating control.

\* Dimension G is non-fixed dimension, and can be adjusted to match valve dimensions.

\* Dimensions I and J meet ISO5211 flange standard, can match valve dimensions.

### Electric Control Solution

#### Technical Parameters of ET & RM Series Electric Actuators:

Figure	Maximum Output Torque	Butterfly Valve Dimension HB950	Acting Time (Sec)		ISO5211	Weight	
	Nm		mm	AC110/220/380V		AC/DC24V	Lbs.
ET/RM050H-090H	35	40 - 80	11	8	F03/05/07	7	3
ET/RM-120	80	100	22	15	F03/05/07	8	4
ET/RM-130	100	125	19	14	F05/07/10	24	11
ET/RM-160	200	150	39	28	F05/07/10	24	11
ET/RM-235	400	200	29	21	F10/12/14	49	22
ET/RM-300	600	250	39	28	F10/12/14	49	22
ET/RM-400	800	300	47	34	F10/12/14	49	22
ET/RM-635	1000	350	47	34	F10/12/14	49	22
ET/RM-800	1700	400	34	25	F12/14/16	79	36
ET/RM-835	1700	450	34	25	F12/14/16	798	36
ET/RM-900	2300	500	47	34	F12/14/16	79	36
ET/RM-1200	3500	600	76	55	F14/16	168	76
ET/RM-1300	5000	-	105	78	F14/16	168	76

\* ET for ON/OFF control; RM for regulating control.

\* Rated torque: 75% of maximum torque.

\* On/off time of 60 Hz actuator: 5/6 of on/off time of 54 Hz actuator; maximum output torque: ditto.

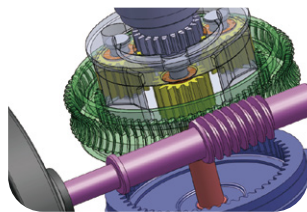

Shell	IP67 (factory standard), IP68NEMA4/4X6/6P, 72h at 15 m underwater
Power Supply of Motor	AC 110~120 V/AC 220 V~240 V/AC 380~440 V & AC/DC 24 V, 50/60 Hz
Efficient Motor	Rated working time: > 30 min, energy consumption reduced by over 30%, protection grade: Grade F
Over-Temperature Control	The motor is equipped with the temperature control switch which works to power the motor off automatically to protect the motor in case of excessive torque.
Control Signal	4-20 mA/2-10 V/0-10 V input/output
Emergency Gear	Automatic switching between manual and electric operation, without the help of the clutch
Switch Indicator	PoHS-based plastic 3D indicator with high strength and resistance to sunlight, enabling view of switch stroke at 360°
Sealed Structure	The shell and body are with enclosed-seal, highly applicable to use outdoors or underwater
Stroke	90° stroke
Interchangeable Splines	Square holes and keyways with different dimensions for connection available
Self-Lock Device	A combination of an internal gear and a planetary gear, worm gear lever for manual transmission, with self-locking function
Terminal Box	An independent terminal box, with no need to open the shell of the actuator
Work Environment	Free from highly corrosive, flammable and explosive media
Ambient Temperature	-25°C~+70°C
Relative Humidity	90% (25°C)
Material	Hard aluminum alloy
Outer Coating	Dry powder, epoxy polyester

\* Electric actuators are all equipped with damp-proof resistors to prevent moisture condensation inside shells.

\* Protection grade for motors: Grade F (standard); Grade H (optional)

### Conversion Tables

Size	In	1/8	1/4	3/8	1/2	3/4	1	1 1/4	1 1/2	2	2 1/2	3	4	5	6	8	10	12	14	16
	DN	4	6	10	15	20	25	32	40	50	65	80	100	125	150	200	250	300	350	400
	In	18	20	24	26	28	30	32	34	36	42	48	54	60	64	72	80	84	88	96
	DN	450	500	600	650	700	750	800	850	900	1050	1200	1350	1500	1600	1800	2000	2100	2200	2400
Pressure	PSI	Pounds Per Sq.In.							0.069				Bar				Bar			
	PSI	Pounds Per Sq.In.							6.89				Kilopascals				Kpa			
	PSI	Pounds Per Sq.In.							0.07				Kilogram Per Sq.Centimeter				Kg/Cm <sup>2</sup>			
	Lb./Ft. <sup>2</sup>	Pounds Per Sq.Ft.							4.88				Kilogram Per Sq.Meter				Kg/m <sup>2</sup>			
	Kpa	Kilopascals							0.145				Pounds Per Sq.In.				PSI			
	Kg/Cm <sup>2</sup>	Kilogram Per Sq.Centimeter							14.22				Pounds Per Sq.In.				PSI			
	Bar	Pounds Per Sq.In.							0.069				Bar				Bar			
Length	In	Inches							2.54				Centimeters				Cm			
	Ft	Feet							30.48				Centimeters				Cm			
	mm	Millimeters							0.03937				Inches				In			
	Cm	Centimeters							0.3937				Inches				In			
	m	Meters							3.2808				Feet				Ft			
Mass	Oz	Ounces							28.35				Grams				G			
	Lb	Pound							0.4536				Kilograms				Kg			
	G	Grams							0.03527				Ounces				Oz			
	Kg	Kilograms							2.205				Pound				Lb			
Temperature	°F	Fahrenheit							(°F-32) *5/9				Celsius				°C			
	°C	Celsius							°C*9/5+32				Fahrenheit				°F			
Area	In <sup>2</sup>	Square Inches							6.45				Square Centimeters				Cm <sup>2</sup>			
	Ft <sup>2</sup>	Square Feet							0.0929				Square Meters				m <sup>2</sup>			
	Cm <sup>2</sup>	Square Centimeters							0.155				Square Inches				In <sup>2</sup>			
Volume	Fl.Oz	Fluid Ounces							29.5625				Milliliters				ML			
	Qt	Quart							0.946				Liters				L			
	Gal	Gallons							3.785				Liters				L			
	Ft <sup>3</sup>	Cubic Feet							0.0283				Cubic Meters				M <sup>3</sup>			
	ML	Milliliters							0.0338				Fluid Ounces				Fl.Oz			
	L	Liters							1.0571				Quart				Qts			
	L	Liters							0.2642				Gallons				Gal			
	M <sup>3</sup>	Cubic Meters							35.34				Cubic Feet				Ft <sup>3</sup>			
In <sup>3</sup>	Cubic Inches							5.787*10 <sup>-4</sup>				Cubic Feet				Ft <sup>3</sup>				

### Valve Installation Tips

Before installing valves, please read the following installation instructions to avoid damage to valves and ensure that the valves can perform perfectly.

#### 1. Threaded Connection

1. Grit, dirt and foreign particles in pipes may impair the operating efficiency of valves and damage their key parts seriously. Hence, it is required to clean pipes thoroughly with air or steam.
2. When threading pipes, measure the dimension and length of pipe threads to avoid jamming pipes against valve seats and discs. Clean threaded ends thoroughly to remove harmful steel or iron deposits. For firmer welding, PTFE tapes or pipe adhesives may be used. However only small amount of pipe adhesive is allowed on pipe threads. As for valve thread, no pipe adhesive is allowed. Stop pipe adhesives from flowing into valves to avoid damage to discs and seats.
3. Before installation cut off fluid that flows through valves to ensure valves function normally. Close valves completely before installation. Apply wrenches to hexagon bolt heads close to pipes and guard against possible deformation. Brace support the pipelines after valve installation as sagging pipes may deform valves and cause valve failure.

#### 2. Flanged Connection

Please follow the steps below to ensure proper flanged connection. Clean connections carefully; mount two or three bolts loosely on the seat; insert gaskets into connections carefully and retain the gaskets at proper position with the help of bolts on the seat; screw bolts in a cross-over manner to eliminate concentrated stress. After service for a certain time, check all bolts and tighten them if necessary.

**Table of Flange Dimensions for EN1092 Butterfly Valves**

mm	50	65	80	100	125	150	200	250	300	350	400	450	500	600
In	2	2½	3	4	5	6	8	10	12	14	16	18	20	24
D1	50	65	80	100	125	150	208	255	308	340	405	455	505	605
D2	61	78	91	116	142	170	221	275	327	358	408	462	513	616
D3	99	118	132	156	184	211	266	319	370	429	480	548	609	720
D4	125	145	160	180	210	240	295	355	410	470	525	585	650	770
D5	165	185	200	220	250	285	340	405	460	520	580	640	715	840
b	19	20	20	20	20	20	20	22	24	26	28	30	31.5	36
f	3	3	3	3	3	3	3	3	4	4	4	4	4	5
T	5	6	6	6	6	6	8	10	10	11	11	11	11	11
n-d	4-19	4-19	8-19	8-19	8-19	8-23	12-23	12-28	12-28	16-28	16-31	20-31	20-34	20-37

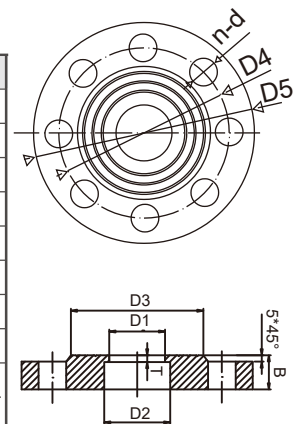

**Dimensions of ISO5211 Upper Flange and Flat Spindle Heads**

mm	50	65	80	100	125	150	200	250	300	350	400	450	500	600
In	2	2½	3	4	5	6	8	10	12	14	16	18	20	24
ISO5211	F07	F07	F07	F07	F07	F07	F10	F10	F10	F10	F14	F14	F14	F16
B	90	90	90	90	90	90	125	125	125	125	175	175	175	210
C	70	70	70	70	70	70	102	102	102	102	140	140	140	165
D	55	55	55	55	55	55	70	70	70	70	100	100	100	130
D1	4-φ10	4-φ10	4-φ10	4-φ10	4-φ10	4-φ10	4-φ12	4-φ12	4-φ12	4-φ12	4-φ18	4-φ18	4-φ18	4-φ23
D2	9	9	9	11	14	14	17	22	24	24	27	27	32	36
d0	12.6	12.6	12.6	15.77	18.92	18.92	22.1	28.45	31.6	31.6	37.95	42.86	45.72	53.98
L	30	30	30	30	30	30	40	40	40	45	52	52	65	70

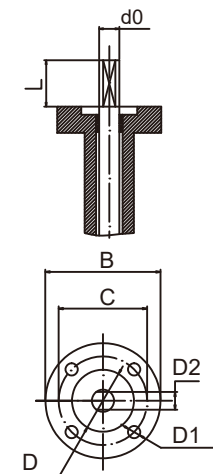

# How to Order

### To Whom It May Concern :

As suggested, please have a good understanding of the technical features of our products before placing orders so as to purchase proper products. Please provide the following product information when ordering:

- Valve type, material, end type, dimensions and quantity
- Fluid media, temperature and maximum working pressure
- Materials of seals, discs and valve shafts inside body
- Operating modes of valves
- Requirements for product package, transportation and delivery date
- Other special requirements

Alternatively, please feel free to browse products at [www.taloar.com](http://www.taloar.com). For special specifications not covered in the brochure, please consult TALOAR's representative office.



### Notes:

\* TALOAR will bear no liability for any consequences arising out of users' failure to select proper products or to provide accurate product application information.

\* In order to protect your legitimate rights and interests, please purchase our products through authorized dealers.

### Material Performance of Rubber Seats:

Material	Temperature Range °C	Notes
NBR	- 23°C~82°C	NBR has good ductility and resistance to wearing and hydrocarbons. It is usually applicable to media such as water, vacuum gas, acid, salt, alkali, oil and glycol, but it should not be used for media such as acetone, ketone, nitrate and fluorinated hydrocarbon.
EPDM	- 40°C~135°C	EPDM is a kind of commonly-used favorable synthetic rubber. It is applicable to media such as cold/hot water, beverages, dairy products, ketone, alcohol, nitrate ester and glycerin, but it should not be used for media such as hydrocarbon-based oil, inorganic substance and solvent.
VITON	- 29°C~205°C	VITON refers to fluorinated hydrocarbon rubber that comes from good hydrocarbon-resistant oil, oily gas and other petroleum products. It is applicable to water, oil, air and acid media, but it should not be used for such media as steam, hot water above 150°C and concentrated alkaline.
MQ	- 40°C~180°C	MQ has good resistance to high/low temperature and stable chemical properties. It is widely applied in strong acid, weak base and food industries.
PTFE	- 10°C~200°C	PTFE has stable chemical properties, outstanding non-viscidty on the surface, satisfactory lubricity and good resistance to aging. It is widely used for strong acid, strong base, strong oxidant and other corrosive media.

### Common Codes:

<b>BB</b>	Bolted Bonnet	<b>IN</b>	Inch	<b>SE</b>	Screwed (Threaded) End
<b>BW</b>	Butt Welding	<b>IN LB</b>	Inch-pound	<b>SJ</b>	Solder Joint
<b>BR</b>	Bronze	<b>IBBM</b>	Iron Body Bronze Mounted	<b>SS</b>	Stainless Steel
<b>B/M</b>	Bill of Material	<b>IPS</b>	Iron Pipe Size	<b>STL</b>	Stellite
<b>CI</b>	Cast Iron	<b>MAX</b>	Maximum	<b>SWP</b>	Steam Working Pressure
<b>CS</b>	Cast Steel	<b>MIN</b>	Minimum	<b>STD</b>	Standard
<b>CWP</b>	Cold Working Pressure	<b>NPT</b>	National Pipe Thread	<b>SB</b>	Screw Bonnet
<b>CV</b>	Check Valve	<b>NRS</b>	Non-Rising Stem	<b>UB</b>	Union Bonnet
<b>D</b>	Dual-disc	<b>OD</b>	Outer Diameter	<b>VAC</b>	Vacuum
<b>FLG</b>	Flanged End	<b>OS&amp;Y</b>	Outside Screw & Yoke	<b>WWP</b>	Water Working Pressure
<b>FF</b>	Flat Face	<b>PSI</b>	Pounds Per Square Inch	<b>WB</b>	Welded Bonnet
<b>°F</b>	Fahrenheit	<b>RF</b>	Raised Face Flange	<b>WOG</b>	Water, Oil, Gas
<b>FS</b>	Forged Steel	<b>RS</b>	Rising Stem	<b>TEMP</b>	Temperature



# TALOAR<sup>®</sup>

www.taloar.com

TALOAR INC.,

1220 N. Market Street,  
Delaware, USA.  
PHONE: +1/302.327.8999  
www.taloar.com

\* For any data errors or questions, contact the manufacturer.  
\* TALOAR reserves the right to change drawings, content, modifying or data updating herein without further notice.

